

## 6 problems for 100 pts

## Problem #1: Constant Current Source (18 pts)

Suppose we need to drive a motor in constant torque mode, which means it needs a fixed current rather than a voltage. Consider the constant current source shown in the figure. It works like this: The op amp's (+) input is two diode drops below +Vcc. The Q1 emitter current depends on R1, while the load current comes from Q1's collector.

The design constraints are the following:

- The motor is rated at 200 mA @ 6V
- $V_{cc} = 12V$
- The op amp is an LF356
- The diodes are 1N914
- Q1 is either a 2N4403 or TIP30G
- R1 and R2 must be standard 5% resistors

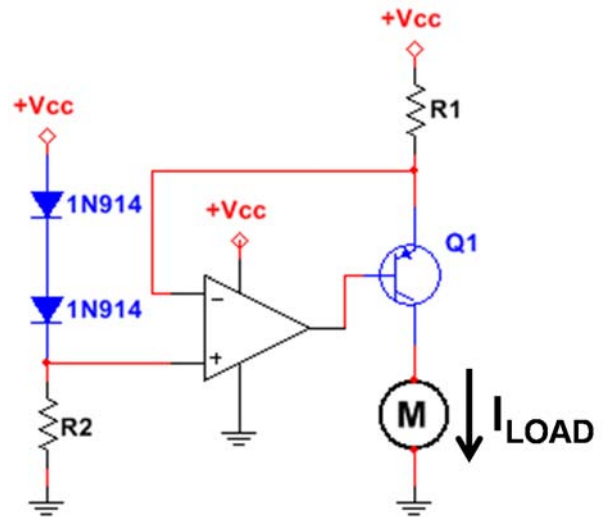

- Assuming typical 1N914 conditions, choose the appropriate value for R2.
- Perform a “quick” analysis to choose Q1. You must explain why you chose one transistor and not the other!
- Choose R1, based on **typical Q1 conditions**.
- Show that the op amp can produce the required output voltage and current, even under **worst case Q1 conditions**.
- Suppose  $V_{cc}$  comes from a battery, which means  $V_{cc}$  will decrease as the battery is drained. What is the smallest value of  $V_{cc}$  that allows proper current source operation? Assume **worst-case Q1 conditions**.

(extra sheet for work)

## Problem #2: Muscle Wire Controller (18 pts)

Consider a robotics application involving “muscle wire”, which is made of a special nickel-titanium alloy. Muscle wire requires electrical current to produce a contraction. The microcontroller, transistor switch, and muscle wire are all operated from the same  $V_{CC} = 3.5V$  power supply. From an electrical viewpoint, muscle wire is just a resistor. The design constraints are the following:

- Muscle wire rating is 1.5A @ 3.5V
- Microcontroller unit (MCU): 3.5V logic and max  $I_{OUT} = 20\text{ mA}$
- Available transistors are: TIP31, TIP120, IRF510
- Any resistors must be standard 5% value.

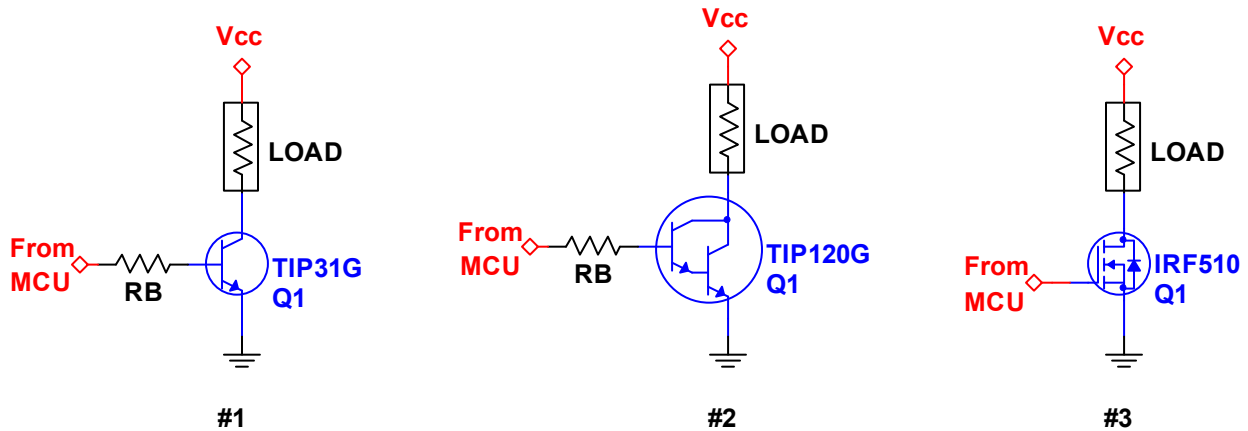

- Explain why Circuit #2 works while the other two do not.
- Assuming typical Q1 conditions, compute the load current and choose the appropriate value for RB.
- Assuming typical Q1 conditions, compute the power dissipation in the muscle wire.
- Assuming typical Q1 conditions, does Q1 need a heat sink?

(extra sheet for work)

## Problem #3: Heater Controller (18 pts)

You are asked to design a heating system for an egg incubator. The heater is operated with a PWM controller. If the temperature drops below  $T_{\text{MIN}} = 35^{\circ}\text{C}$ , then the heater should be on all the time. If the temperature rises above  $T_{\text{MAX}} = 40^{\circ}\text{C}$ , then the heater should be completely off. The design constraints are the following:

- Temp sensor:  $V_{\text{sig}}$  increases with temperature ( $V_{\text{sig}} = 1\text{V}$  for  $T_{\text{MIN}} = 35^{\circ}\text{C}$ ;  $V_{\text{sig}} = 3\text{V}$  for  $T_{\text{MAX}} = 40^{\circ}\text{C}$ ).
- The ramp waveform goes from 1 to 3V at 2 kHz.
- $V_{\text{CC}} = 15\text{V}$
- Heater is rated at 15V @ 18W and driven by three parallel IRFD9210 p-channel MOSFETs

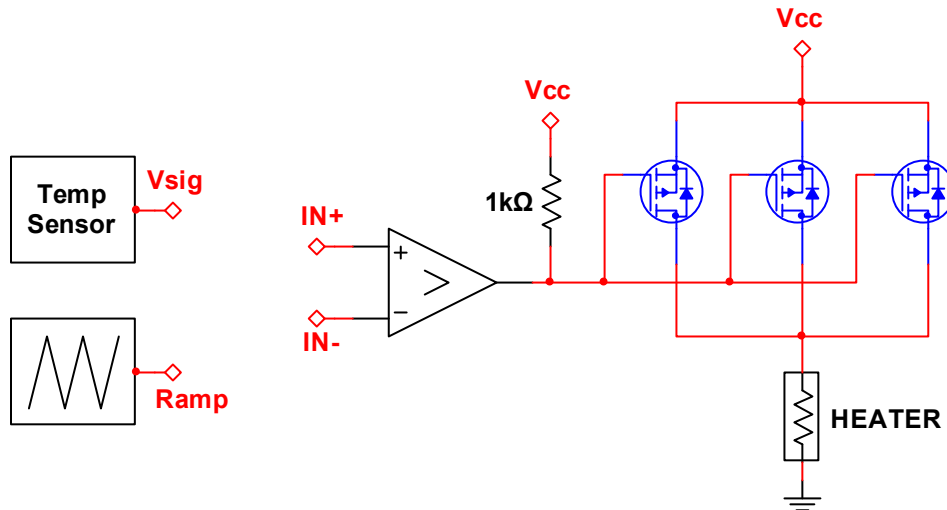

- Explain the rationale for how would you connect  $V_{\text{sig}}$  and Ramp to the comparator.
- Assuming the heater is always ON, do the MOSFETs need heat sinks? Assume all three MOSFETs have identical  $R_{\text{DS,ON}}$  and assume typical transistor conditions. Show all work!
- Suppose  $V_{\text{sig}} = 1.5\text{V}$ . Sketch the ramp waveform, comparator output, and the heater current over a 2 ms interval. Label your axes and important features!

(extra sheet for work)

## Problem #4: Inverting Amplifier + Low-pass Filter (18 pts)

The circuit to the right combines an inverting amplifier with a low-pass filter. The amplifier gain is  $V_{OUT}/V_{IN} = -R_2/R_1$  at DC. However, the capacitor causes  $|V_{OUT}/V_{IN}|$  to decrease with higher frequency.

Suppose the design requirements are the following:

- $|G| = 40$  dB at DC
- $|G| = 0$  dB ( $\pm 1$  dB) at 40 kHz
- Input impedance  $Z_{IN} \geq 10$  kohm
- Use only standard 5% resistors and 10% capacitors.

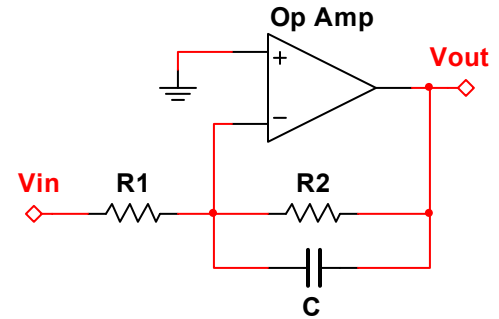

(a) Use the Golden Rules to show that:

$$|G| = \left| \frac{V_{OUT}}{V_{IN}} \right| = \frac{R_2}{R_1} \frac{1}{\sqrt{1+(f/f_c)^2}}$$

Make sure to clearly derive the cut-off frequency  $f_c$ !

- (b) Choose the appropriate values for  $R_1$ ,  $R_2$ , and  $C$ . You must clearly show that the design specs have been satisfied!
- (c) Suppose  $V_{IN} = 0.05 + 0.5\sin(2\pi f_0 t)$ , where  $f_0 = 40$  kHz. Sketch both  $V_{IN}$  and  $V_{OUT}$  over a 75  $\mu$ s interval. Label all axes and important features!

(extra sheet for work)



## Problem #5: Negative Feedback (14 pts)

Consider a voltage buffer using an op amp with  $R_i = 200 \text{ kohm}$  and  $R_o = 150 \text{ ohm}$ . The design requirements are the following:

- Closed-loop gain is no lower than 0.1% below  $G = 1$ .
- Input impedance  $Z_{IN} \geq 1 \text{ Gohm}$
- Output impedance  $Z_{OUT} \leq 20 \text{ milliohm}$

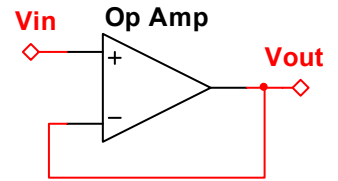

- (a) Assuming an ideal op amp, what is the value of  $\beta$ ?
- (b) What is the minimum acceptable open-loop gain  $A_o$  of the op amp? Remember that you must satisfy all three requirements!
- (c) Would the LF356 op amp be acceptable even under worst-case conditions? Show all work!
- (d) Suppose  $V_{in}$  comes from a sensor with a source impedance of  $Z_s = 50 \text{ kohm}$ . Sketch a modified circuit that minimizes output voltage error.

(extra sheet for work)

## Problem #6: Amplifier Stability (14 pts)

Consider the non-inverting amplifier shown to the right. The op amp has an open-loop DC gain of 10 V/mV and poles at 30 kHz and 30 MHz.

- Sketch the Bode plots for the magnitude and phase of the open-loop gain from 3 Hz out to 300 MHz. Label important features!
- On your Bode plot for  $|A|$ , sketch  $1/\beta$  and explain if the amplifier is stable or not.
- Suppose you want to make a buffer. Compute the phase margin of the buffer and explain if it is stable or not.

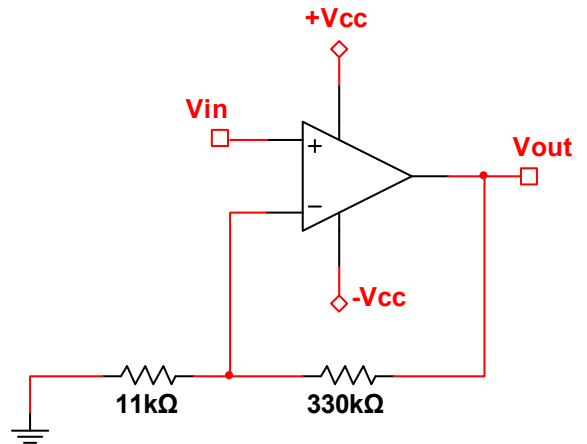

(extra sheet for work)

Standard Resistor Values ( $\pm 5\%$ )						
1.0	10	100	1.0K	10K	100K	1.0M
1.1	11	110	1.1K	11K	110K	1.1M
1.2	12	120	1.2K	12K	120K	1.2M
1.3	13	130	1.3K	13K	130K	1.3M
1.5	15	150	1.5K	15K	150K	1.5M
1.6	16	160	1.6K	16K	160K	1.6M
1.8	18	180	1.8K	18K	180K	1.8M
2.0	20	200	2.0K	20K	200K	2.0M
2.2	22	220	2.2K	22K	220K	2.2M
2.4	24	240	2.4K	24K	240K	2.4M
2.7	27	270	2.7K	27K	270K	2.7M
3.0	30	300	3.0K	30K	300K	3.0M
3.3	33	330	3.3K	33K	330K	3.3M
3.6	36	360	3.6K	36K	360K	3.6M
3.9	39	390	3.9K	39K	390K	3.9M
4.3	43	430	4.3K	43K	430K	4.3M
4.7	47	470	4.7K	47K	470K	4.7M
5.1	51	510	5.1K	51K	510K	5.1M
5.6	56	560	5.6K	56K	560K	5.6M
6.2	62	620	6.2K	62K	620K	6.2M
6.8	68	680	6.8K	68K	680K	6.8M
7.5	75	750	7.5K	75K	750K	7.5M
8.2	82	820	8.2K	82K	820K	8.2M
9.1	91	910	9.1K	91K	910K	9.1M

Standard Capacitor Values ( $\pm 10\%$ )						
10pF	100pF	1000pF	.010 $\mu$ F	.10 $\mu$ F	1.0 $\mu$ F	10 $\mu$ F
12pF	120pF	1200pF	.012 $\mu$ F	.12 $\mu$ F	1.2 $\mu$ F	
15pF	150pF	1500pF	.015 $\mu$ F	.15 $\mu$ F	1.5 $\mu$ F	
18pF	180pF	1800pF	.018 $\mu$ F	.18 $\mu$ F	1.8 $\mu$ F	
22pF	220pF	2200pF	.022 $\mu$ F	.22 $\mu$ F	2.2 $\mu$ F	22 $\mu$ F
27pF	270pF	2700pF	.027 $\mu$ F	.27 $\mu$ F	2.7 $\mu$ F	
33pF	330pF	3300pF	.033 $\mu$ F	.33 $\mu$ F	3.3 $\mu$ F	33 $\mu$ F
39pF	390pF	3900pF	.039 $\mu$ F	.39 $\mu$ F	3.9 $\mu$ F	
47pF	470pF	4700pF	.047 $\mu$ F	.47 $\mu$ F	4.7 $\mu$ F	47 $\mu$ F
56pF	560pF	5600pF	.056 $\mu$ F	.56 $\mu$ F	5.6 $\mu$ F	
68pF	680pF	6800pF	.068 $\mu$ F	.68 $\mu$ F	6.8 $\mu$ F	
82pF	820pF	8200pF	.082 $\mu$ F	.82 $\mu$ F	8.2 $\mu$ F	