

MOHAWK WATERSHED SYMPOSIUM

2012



ABSTRACTS AND PROGRAM

**COLLEGE PARK HALL
UNION COLLEGE
SCHENECTADY NY
16 MARCH 2012**

PREFACE

The Geology Department at Union College is pleased to host the fourth Mohawk Watershed symposium. While the upper basin has been recovering from the 2006 floods, the lower basin sustained tremendous damage from the one-two punch of flooding from Hurricane Irene (28-29 August, 2011) and Tropical Storm Lee (10 September, 2011).

Historic and epic flooding in the Schoharie Creek has changed the political, economic, and physical landscape in a deep and profound way. More than ever, we are reminded of the importance of bringing key stakeholders together to present studies, develop strategies, and exchange ideas in a formal but relaxed forum that has emerged from the Mohawk Watershed series at Union College.

This year we have given incredible focus on the workings and impacts of the storms that hit the southern part of the watershed in late August and early September. In addition to the Schoharie County Soil and Water Conservation District perspective, we will also have here from the National Weather Service to understand the meteorological and hydrological properties of these events. The New York State Canal Corporation will detail the enormous amount of damage and change that was seen within the main channel of the Mohawk River. Several presentations discuss the significance of these storms in a context of understanding extremes beyond the instrumental record. Incredible effort and work have gone into understanding these events in the basin and its sub-catchments and both invited and volunteered presentations will help describe the impacts and imprints these events had on the watershed.

We are pleased to have NYS Assemblyman Peter Lopez from the NY 127th Assembly District as the Keynote speaker this year. Assemblyman Lopez represents Schoharie and other towns and villages in the upper part of the Schoharie watershed that were particularly hard hit by Irene flooding. He has been a strong vocal advocate for transparency in the operation of dams in this part of the watershed, and he has worked for tax relief for flood victims who have sustained considerable personal and property losses from the floods. He provides a unique perspective on the political landscape following these devastating floods.

As many work to develop a watershed management plan, and as communities look for waterfront development ideas, we continue to ask questions about the hydrology of the basin and how that is changing over time. A key challenge, therefore is to develop and manage a watershed that appears to be a complex system that is changing and dynamic. Hydrological data suggest more water is entering the watershed and in a variable and complex way. This is the fourth annual symposium on the Mohawk Watershed and we are delighted to host this full program of talks and posters that cover a wide range of topics. Here at Union College, we are proud to help serve as a catalyst for initiating and fostering those conversations that will hopefully drive positive change in the watershed.

We are indebted to our sponsors this year who have helped defray the cost of running the symposium: Union College, Brookfield Renewable Energy Partners, U.S. Geological Survey, NYS DEC, Cornell, and NY State Water Resources Institute. We hope that the continued spirit of information exchange and interaction will foster a new and better understanding of the intersection between Science, Engineering, and Policy in the watershed.

John I. Garver

Jaclyn Cockburn

On the cover: Lock 10, Cranesville (NY) after breach that occurred during flooding related to the remnants of Tropical storm Lee, 10 September 2011. Locks 8, 9, and 10 had similar failure during the floodwaters related to flooding first initiated by rain and flooding associated with Hurricane Irene and then Tropical storm Lee. Lock 10 is notable because the River flowed around the lock structure in 2006 and extensive repairs were required after that event – the new structures and spillway can be seen in the middle ground of the photo. Photo: J.I. Garver, Geology Department, Union College.

© 2012 Geology Department, Union College, Schenectady N.Y. 12308-3107. All rights reserved. No part of the document can be copied and/or redistributed, electronically or otherwise, without written permission from the Geology Department, Union College, Schenectady NY, 12308-2311, USA.

Digital version of MWS 2012 abstract volume available as a free PDF download format from:
<http://minerva.union.edu/garverj/mws/2012/symposium.html>

MAJOR FINANCIAL SUPPORT FOR MWS 2012



Redefining Liberal Education for the 21st Century. Founded in 1795, Union College was the first college chartered by the Board of Regents of the State of New York. We are a small, independent liberal arts college committed to integrating the humanities and social sciences with science and engineering in new and exciting ways. Union's rigorous academics take place in a diverse, welcoming campus environment that supports your personal growth, provides you with a wealth of opportunities to find and pursue your passions, and inspires you to engage with the local and global community through meaningful projects and volunteer work.

Brookfield

Brookfield Renewable Energy Group (TSX: BEP.UN) operates one of the largest publicly-traded, pure-play renewable power platforms in the world. Its portfolio is comprised of 172 hydropower facilities and seven wind farms, totaling approximately 5,000 megawatts of installed capacity. Diversified across 67 river systems and 10 power markets in Canada, the United States and Brazil, the portfolio generates enough electricity from renewable resources to power two million homes on average each year. In New York, Brookfield owns and operates 75 hydropower facilities, over half of which have been designated as environmentally low-impact by the independent Low Impact Hydropower Institute. For more information, please visit www.brookfieldrenewable.com.

FINANCIAL SUPPORT FOR MWS 2012 ALSO FROM:



The USGS New York Water Science Center operates the most extensive satellite network of stream- and tide-gaging stations in the state, many of which form the backbone of flood-warning systems. The USGS provides current ("real-time") stream stage and surface-water, water-quality, and groundwater levels for over 300 sites in New York.

The Mohawk River Basin Program (MRBP) is a multi-disciplinary environmental management program focused on conserving, preserving and restoring the environmental, economic, and cultural elements of the Mohawk River Watershed. Through facilitation of partnerships among local, state and federal governments, the MRBP works to achieve the goals outlined in the Mohawk River Basin Action Agenda (2012-2016). The MRBP sees the continuation of the Union College Mohawk Watershed Symposium as an ideal platform for communication among stakeholders at all levels.

The MRBP partners with organizations such as the New York State Water Resources Institute (WRI), a government mandated institution located at Cornell University, whose mission is to improve the management of water resources. This year, through the cooperative relationship between the MRBP and Cornell University (WRI), funding and personnel (Katherine Czajkowski) was offered to help support and sponsor the Symposium.



New York State Department of
Environmental Conservation



Cornell University



Mohawk Watershed Symposium - 2012
16 March 2012, College Park, Union College, Schenectady NY

- 2012 Schedule -

Friday 16 March 2012

Oral session (College Park) - Registration and Badges required

8:30 9:00 Registration, Coffee. College Park

9:00 9:05 Introductory remarks

John I. Garver, Geology Department, Union College

9:05 9:33 Meteorological Factors that Resulted in Extreme Rainfall During Tropical Storm Irene (Invited)

Joseph Villani, Stephen DiRienzo (Speaker), Hugh Johnson, Vasil Koleci, Kevin Lipton, George Maglaras, Kimberly McMahon, Timothy Scrom, Thomas Wasula, and Britt Westergard, NOAA/NWS Weather Forecast Office, Albany, New York

9:33 10:01 Hydrology of Tropical Storms Irene and Lee (Invited)

Britt Westergard (Speaker), Joseph Villani, Stephen DiRienzo, Hugh Johnson, Vasil Koleci, Kevin Lipton, George Maglaras, Kimberly McMahon, Timothy Scrom, and Thomas Wasula, NOAA/NWS Weather Forecast Office, Albany, New York

10:01 10:16 Rethinking forecasted impacts of gradual climate change in the Mohawk Watershed and other northeastern watersheds: Extreme events vs gradual change

Jaclyn Cockburn, Geography Department, University of Guelph and John I. Garver, Geology Department, Union College

10:16 10:44 How Extreme was Irene? A Comparison of the 2011, 1996 and 1987 Floods along the Schoharie Creek (Invited)

Chris Gazoorian, U.S. Geological Survey, New York Water Science Center

10:44 11:14 COFFEE and POSTERS (see below for listing)

11:14 11:42 In Irene's and Lee's Wake: Putting the Pieces and Places of the Erie Canal Back Together (Invited)

Brian Stratton, New York State Canal Corporation

11:42 11:57 Change in the Mohawk Watershed and Vulnerability to Infrastructure

John I. Garver, Geology Department, Union College and Jaclyn Cockburn, Geography Department, University of Guelph

11:57 12:12 Instrumentation in the Gilboa Dam

Howard Bartholomew, Dam Concerned Citizens

12:12 12:27 Degradation and Aggradation Along the Mohawk River and the Schoharie Creek

Ashraf Ghaly, Engineering, Union College

12:27 12:55 Post Flood Recovery Efforts in Schoharie County from a Conservation Districts Vantage Point (Invited)

Peter Nichols, Schoharie County Soil and Water Conservation District

**12:55 14:15 - LUNCH and Breakout Sessions -- See abstract volume for Breakout Session Details -
Lunch provided at College Park**

14:15 14:35 Breakout reports

Facilitator: Jaclyn Cockburn

14:35 15:03 New York's Shale Plays and Water Resources (Invited)

John Williams, United States Geological Survey

15:03 15:18 An Urban Waters Program Proposal – Bioassessment, youth training, and post-flood riparian recovery of the Schoharie and lower Mohawk Watershed – A Call for Investors

John McKeeby, Schoharie River Center

15:18 15:46 NYSDEC Mohawk River Basin Program: Building Collaborations and Partnerships in the Basin (Invited)

Alexander J. Smith and Katherine Czajkowski, New York State Department of Environmental Conservation

15:46 16:16 **COFFEE and POSTERS (see below for listing)**

16:16 16:31 **Mohawk River Watershed Management Plan Progress Report: Inventory of Physical Features, Land Use, and Pollution Sources Using GIS**

Dave Mosher and Katie Budreski, Mohawk River Watershed Coalition of Conservation Districts

16:31 16:46 **Mohawk River Watershed Management Plan: Assessment Phase of Watershed Characterization**

Win McIntyre, Mohawk River Watershed Coalition of Conservation Districts

16:46 17:14 **Mighty Waters (Invited)**

Congressman P.D. Tonko, New York's 21 Congressional District

17:14 17:29 **Closing Remarks**

Jaclyn Cockburn, Geography Department, University of Guelph

Poster session (all day)

P1 Stream Gages on the Schoharie Creek and its Tributaries

Sherry Bartholomew, Howard Bartholomew, Alexander Bartholomew, DCC

P2 Monitoring small-scale bedload transport using Passive Integrated Transponders (PIT)

Garnet Cornell, Dylan Gillingham, Geography Department, University of Guelph

P3 An insight into shoreline damage due to stormwater surge

Ashraf Ghaly, Engineering, Union College

P4 Post-Irene suspended sediment dynamics in Schoharie Creek

David Gillikin, John Garver, Geology Department, Union College and John McKeeby, Schoharie River Center

P5 A Post Hurricane Irene Rapid Bioassessment of the Water Quality of the Schoharie Creek At Burtonsville

Mary Rachel Keville, Jacob Tanzman, Corrine Skala, Nick Marotta, Nick Lynch and John McKeeby, Schoharie River Center, Environmental Study Team

P6 Wind Erosion Control, Optimisation Based on Array and Density

Jason Krompart, Peter Nowell, Geography Department, University of Guelph

P7 Escaping Inundation: The Canoeing Adventure of a Lifetime

Elizabeth Morgan, Boy Scouts of America and Drew Pearson, Wildwood School

P8 Majors Floods of 2011 in New York

Thomas Suro, United States Geological Survey

P9 A Catalogue of Groups Working on Water Issues in Schenectady County

Mary Werner, Schenectady County Environmental Advisory Committee

P10 The Sedimentary Record of Mohawk River Floods Preserved in Collins Pond, Scotia NY, Confirmed by Hurricane Irene

John Farrell and Don Rodbell, Geology Department, Union College

Symposium Reception (Old Chapel) 5:30pm-6:30pm

Old Chapel is on the main part of the campus, limited parking near the building is available

Symposium Banquet (Old Chapel) 6:30pm - 8:30pm, registration and tickets required

Keynote Address - Responding to Disaster: Stories and lessons learned from the 2011 summer storms

Assemblyman Peter Lopez

**KEYNOTE ADDRESS AT THE BANQUET (OLD CHAPEL)
ASSEMBLYMAN PETER LOPEZ**

Responding to Disaster: Stories and lessons learned from the 2011 summer storms

Peter Lopez was elected as Assemblyman for the 127th Assembly District on November 7, 2006. The son of a working class family, Pete scrubbed floors, stocked store shelves, baled hay and scraped fish -- all in the hope of funding his college education and building a future in New York State.

Pete has served as Schoharie County Clerk since 2004 and previously served on the staff of the New York State Legislature for 21 years, where he worked with a broad range of public and private interests at the federal, state and local levels to improve the quality of life for the people of New York State.

As Associate Director of the Senate Agriculture Committee, Assistant Director of the Legislative Commission on Rural Resources, District Office Director for Assembly Minority Leader John J. Faso and Executive Assistant to Senator John J. Bonacic, he helped develop legislation and budget proposals, assisted with agency regulatory review, served on interagency advisory committees, responded to individual constituent needs, and advanced community projects.



In addition to his term as Schoharie County Clerk, Pete also served as a village trustee, town councilman and member of the Schoharie County Board of Supervisors. Here, he devoted himself to improving government cost-effectiveness, and worked with many groups and individuals to address pressing local concerns. While holding these offices, Pete was appointed to the Association of Counties' Statewide Transportation Advisory Committee and the Association of Towns' Statewide Legislative Advisory Committee. In recognition of his town and county service, Schoharie County Operation Desert Care awarded Pete the David Williams Award for Preservation of Freedom.

Pete has served extensively in many volunteer service capacities such as altar server trainer, cantor and lector at St. Joseph's and St. Catherine's churches, a community band member, Red Cross water safety instructor, Schoharie Youth Soccer director and coach, Schoharie Central School Ski Club advisor, black belt karate instructor for the Zen Do Kai Martial Arts Association, Eagle Scout project advisor, member of an advisory committee on runaway and troubled youth, and as chairman of the Schoharie Main Street Committee. He was a founding member of Habitat for Humanity of Schoharie County. Additionally, Pete has served as a board member of Bassett Hospital of Schoharie County, Schoharie County Chamber of Commerce, the SUNY Cobleskill Foundation and the SUNY Cobleskill Alumni Association. He received the Distinguished Alumni Award from SUNY Cobleskill, the State University of New York's Golden Anniversary Chancellor's Recognition award, the New York State Masons' General Douglas MacArthur Award for Service to Youth, and, in 2004, the Schoharie County Chamber of Commerce's Leader of the Year Award.

Pete is an honors graduate of Schoharie Central School, the State University College at Cobleskill, and the University at Albany, where he earned a master's degree in public administration. Pete resides on Spring Street in the Village of Schoharie with his wife Lisa, and their children Steffy, Noah and Ben. Their son Brandon is currently working and attending college in Florida.

Several important issues related to floods and flood aftermath have been of Key concerns for Peter. In a meeting in January 2012 with New York Power Authority (NYPA) Chairman and CEO Gil Quiniones, the

Assemblyman advised NYPA of the importance of full disclosure to a community that continues to struggle with the effects of massive flooding from Tropical Storms Irene and Lee.

During the meeting requested by the Power Authority, the Assemblyman emphasized the fears and frustrations of the Schoharie community and the importance of NYPA in taking a proactive stance as he called for full disclosure of the reservoir release records, along with a detailed accounting of the actions and activities taken by the Blenheim-Gilboa Pump Storage Facility during Tropical Storm Irene. In the conversation, Assemblyman Lopez relayed his firsthand knowledge of the event and reports given him from different sources of what transpired at Blenheim-Gilboa during the height of Tropical Storm Irene.

“Many in the community have come to me to share their sense of what happened” said Assemblyman Lopez. “It’s really in everyone’s best interest for NYPA to work with the people of Schoharie County in good faith.”

The Assemblyman made it clear that the public needs to know what was done to protect life and property. He further advised that, while his office was not looking to lay blame, he made it very clear that if these records showed that NYPA’s activities did contribute to the damage, the Authority must be a partner in making those affected whole.

“This is like reviewing the cause and effect of a car accident,” said Assemblyman Lopez. “If someone is driving a vehicle on a road and causes harm to someone else, even if unintended, there’s still a responsibility to pay for the damages.”

As part of the conversation, Assemblyman Lopez also asked NYPA to come forward with recommendations and improvements for protecting the Schoharie Valley from future events, including the construction of cell towers that could strengthen public safety and communications in the future.

“For many years, our emergency responders have struggled with emergency communications in this part of Schoharie County, as well as in northern Greene and Delaware counties,” said Assemblyman Lopez. “If we can leverage money and support from NYPA, the City of New York and others, we might even be able to explore other partnerships that could bring in wireless broadband services for our local homes, farms and businesses.”

In February 2012, he continued to advocate for tax relief for flood victims. In the late summer of 2011, Hurricane Irene and Tropical Storm Lee turned more than half of New York State into a disaster area. In the wake of the storms, families were scattered, farms and businesses crippled, roads, bridges, schools massively damaged – entire regions laid to waste. Six months later, many New Yorkers are still homeless and farms and businesses are still dark. Hundreds of communities across the state wonder whether they can ever fully recover.

Just before Christmas of last year, the legislature and governor authorized \$50 million and a series of other measures intended to bring much-needed relief, gaining the support and thanks of those suffering from the massive impacts of the floods. These measures provided millions in direct grants to farms and businesses to help them rebuild, as well as monies for stabilizing the many streams and creeks that caused the massive damage during the storms.

Along with these and other measures, special authorization was given to schools and local governments to give families and individuals, whose homes were damaged by more than fifty percent from the floods, the ability to receive a direct rebate for property taxes paid in excess of the value of their homes. To exercise the special authority granted them by the governor and legislature, schools and local governments in the declared disaster areas were required to opt into the Real Property Tax (RPT) Rebate Program by January 23rd, 2012.

“The problem is,” said Assemblyman Pete Lopez (R-C-I, Schoharie), whose sprawling seven- county district in the Mid-Hudson, Northern Catskills and Southern Tier was one of the hardest hit, “those communities that are suffering the most can’t afford to give back the money. This issue has pitted

struggling homeowners desperately looking to rebuild against their own neighbors who are working largely as volunteers to keep local schools and government services running.”

“While the intent was good for those communities that were heaviest hit, what the governor and legislature did here is really inhumane – it’s nothing more than a cruel hoax giving the illusion of relief without providing state support,” added Assemblyman Lopez.

Assemblyman Lopez maintains that too many homeowners will not see the benefits, as a number of schools and local governments have come to the difficult decision that giving back the money in the middle of their fiscal year would put them at further financial risk. He further maintains that many who did opt in did so out of compassion for their neighbors, but don’t know how they will make ends meet as they struggle with paying for emergency measures and the continued cost of flood recovery.

“Local governments and schools in areas hit hardest by the floods are writing checks they just can’t pay for,” noted Assemblyman Lopez. “This will be followed by lost tax revenues resulting from the massive damage to properties, which will force drastic reductions in services and shift the tax burden to remaining homeowners and businesses, threatening their ability to make ends meet during the long, fragile recovery period.”

In response, Assemblyman Lopez has made an urgent, statewide plea for help. In a memo to his colleagues in the State Legislature, statewide interest groups representing farms, local governments and businesses, as well as school and local officials, he urges them to reach out to Governor Cuomo to reinforce the Assemblyman’s original request for the state to extend the deadlines and underwrite costs of the RPT Rebate Program.

A number of legislators, including Senators John Bonacic and James Seward, as well as Assembly Members Donna Lupardo, Jack McEneny and Cliff Crouch, already have come forward to help draw attention to the issue, some proposing legislation similar to the bill introduced by Assemblyman Lopez. Discussion among these legislators has centered on targeting aid to those most in need, as well as looking at other options for getting rebates into the hands of distressed property owners. This attention is welcomed by Assemblyman Lopez, who notes that more help is urgently needed if the original goal of the RPT Rebate Program legislation is to be met.

“I am thankful for the efforts made by my colleagues thus far, but we need to draw more attention to this issue if we are to move forward,” said Assemblyman Lopez. “Governor Cuomo and his staff have proven themselves to be compassionate and reliable partners in helping our suffering communities. We need their help to make this happen.”

BREAKOUT SESSIONS

This year we have organized breakout sessions that will occur during the extended lunch hour. Our hope is that interested participants will find a breakout topic of interest, attend, and provide input and direction to these informal and perhaps dynamic discussions. A moderator will facilitate each session and a scribe will record discussion the ideas. We have allotted time for the facilitators to summarize the dialogue of each breakout session to the entire audience after lunch. The concept here is to initiate a discourse between interested stakeholders. The breakout sessions are optional, so if you would rather take your sandwich and enjoy the day outside for a bit, that is fine too.

1. Water Quality - Exploring ways to improve and enhance water quality in the watershed.
Facilitator: Dave Mosher, Schenectady County Soil and Water Conservation District
2. Real-time monitoring networks - Developing, maintaining, and data use for monitoring networks in the basin.
Facilitator: AJ Smith, New York Department of Environmental Conservation
3. The human interface - Developing and maintaining working landscapes, and recreational opportunities, and managing growth and development.
Facilitator: Kevin Millington and Ken Smith, N.Y. Department of State.
4. Floods and flood mitigation - Approaching flood issues including mitigation efforts, vulnerability of infrastructure, and emergency response.
Facilitator: Sean Shortell, District Director, Congressman Paul D. Tonko, 21st District of New York

All session facilitators will report back to the conference after lunch in a short oral summary of the main concerns and theme of the discussions. Assigned scribes who will record comments, thoughts and ideas will aid facilitators. Summaries of each session will be made available on the symposium webpage within a few weeks.

TABLE OF CONTENTS

| | |
|--|-------------|
| Preface | ii |
| Major Financial support for MWS 2012 | iv |
| Sponsors | vi |
| Schedule | vii |
| Keynote | ix |
| Breakout Sessions | xii |
| Table of Contents | xiii |
| | |
| Instrumentation in the Gilboa Dam | |
| <i>Howard R. Bartholomew</i> | 1 |
| Stream Gages on Schoharie Creek and its Tributaries | |
| <i>Sherrie Bartholomew, Howard R. Bartholomew and Alexander Bartholomew</i> | 7 |
| Rethinking forecasted impacts of gradual climate change in the Mohawk Watershed and other northeastern watersheds: Extreme events versus gradual change | |
| <i>Jaclyn Cockburn and John I. Garver</i> | 8 |
| Monitoring Small-scale Bedload Transport using Passive Integrated Transponders (PIT) | |
| <i>Garnet Cornell and Dylan Gillingham</i> | 10 |
| The Sedimentary Record of Mohawk River Floods Preserved in Collins Pond, Scotia, NY Confirmed by Hurricane Irene | |
| <i>John Farrell and Donald Rodbell</i> | 11 |
| Change in the Mohawk Watershed and Vulnerability to Infrastructure | |
| <i>John I. Garver and Jaclyn Cockburn</i> | 12 |
| How Extreme was Irene? A Comparison of the 2011, 1996, 1987 Floods Along the Schoharie Creek | |
| <i>Chris Gazorian</i> | 17 |
| Degradation and Aggradation and Along the Mohawk River and the Schoharie Creek | |
| <i>Ashraf Ghaly</i> | 23 |
| An Insight into Shoreline Damage Due to Stormwater Surge | |
| <i>Ashraf Ghaly</i> | 24 |
| Post-Irene suspended sediment dynamics in Schoharie Creek | |
| <i>David Gillikin, John Garver and John McKeeby</i> | 25 |
| A Post Hurricane Irene Rapid Bioassessment of the Water Quality of the Schoharie Creek at Burtonsville, NY | |
| <i>Mary Rachel Keville, Jacob Tanzman, Corrine Skala, Nick Marotta, Nick Lynch and John McKeeby</i> | 26 |
| Wind Erosion Control, Optimisation based on Array and Density | |
| <i>Jason Krompart and Peter Nowell</i> | 29 |
| Mohawk River Watershed Management Plan: Assessment phase of watershed characteristics | |
| <i>Win McIntyre</i> | 30 |

| | |
|---|----|
| An Urban Waters Program Proposal – Bioassessment, youth training, and post-flood riparian recovery of the Schoharie and lower Mohawk Watershed – A Call for Investors <i>John McKeeby</i> | 31 |
| Escaping Inundation: The Canoeing Adventure of a Lifetime <i>Elizabeth Morgan and Drew Pearson</i> | 32 |
| Mohawk River Watershed Management Plan: Progress Report and Inventory of Physical Features. Landuse and Pollution Sources Using GIS Coalition of Conservation Districts <i>David A. Mosher and Katie Budreski</i> | 33 |
| Post Flood Recovery Efforts in Schoharie County from a Conservation District’s Vantage Point <i>P.M. Nichols</i> | 34 |
| NYSDEC Mohawk River Basin Program: Building Collaboration and Partnerships in the Basin <i>Alexander J. Smith and Katherine Czajkowski</i> | 35 |
| In Irene’s and Lee’s Wake: Putting the Pieces and Places of the Erie Canal Back Together <i>Brian Stratton</i> | 37 |
| Major Floods of 2011 in New York <i>Thomas Suro</i> | 39 |
| Mighty Waters <i>Congressman Paul Tonko</i> | 40 |
| Meteorological Factors that Resulted in Extreme Rainfall During Tropical Storm Irene <i>Joseph Villani, Stephen DiRienzo, Hugh Johnson, Vasil Koleci, Kevin Lipton, George Maglaras, Kimberly McMahon, Timothy Scrom, Thomas Wasula, and Britt Westergard</i> | 41 |
| Schenectady County Water Resources Organizations <i>Mary Werner</i> | 42 |
| The Hydrology of Tropical Storms Irene and Lee <i>Britt Westergard, Joseph Villani, Stephen DiRienzo, Hugh Johnson, Vasil Koleci, Kevin Lipton, George Maglaras, Kimberly McMahon, Timothy Scrom, and Thomas Wasula</i> | 43 |
| New York’s Shale Plays and Water Resources <i>John Williams</i> | 44 |

INSTRUMENTATION IN THE GILBOA DAM

Howard R. Bartholomew

Director Dam Concerned Citizens, Inc., PO Box 310
Middleburgh, NY 12122-0310

In a paper entitled “The Stabilization of Gilboa Dam, New York, Using High Capacity Rock Anchors: Addressing Service Performance Issues:” an explanation of the New York City Department of Environmental Protection’s (NYCDEP) efforts to stabilize the 86 year old Gilboa Dam spillway is made. This paper was written by Kessi E. Zicko and Robert A. Kline, Jr., engineers employed by Gannett Fleming of Harrisburg, Pa. Donald A. Bruce of Geo systems, LP, of Venetia, Pa. collaborated in the preparation of this document.

The Gilboa Dam Spillway is a 1324’ long, 182’ high cyclopean concrete structure. Its elevation above mean sea level is 1130’. Beyond the western limit of the spillway is located an approximately 700’ earthen non-overflow section of the dam containing a concrete core wall. The earthen section of the Gilboa Dam has a crest elevation of 1150’. The concrete spillway was cast in sections or monoliths, which are numbered in sequence 1-17, commencing on the eastern abutment of the dam (Zicko et al. 2007) On the western end of the 1,324’ long overflow spillway section is a notch which is gated with a movable Obermeyer gate that is 220’ long x 5.5’ deep. These dam sections and components comprise the approximately 2000’ long Gilboa dam, which impound the 1142 acre Schoharie Reservoir. The reservoir holds approximately 17.5 billion gallons at “notch level” of 1124.5’ and about 19.5 billions gallons at spillway crest level of 1130’. Gravity dams, such as Gilboa, rely upon structural mass for resistance against the hydraulic forces that are exerted upon them. These forces would displace a gravity dam if the pressure they exert exceeds the dam’s resistance to movement. The high capacity rock anchors referred to in the title of the Zicko, Kline, and Bruce paper are also called post-tensioned anchors. Seventy-nine post-tensioned anchors were installed in the Gilboa Dam spillway in 2006 (Zicko et al. 2007). They are intended to enhance its resistance to forces such as hydrostatic uplift, Nappe Forces, creep,

hydraulic forces on the upstream side of the spillway, etc.

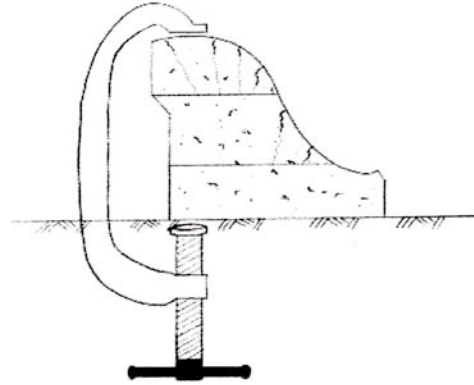

Figure 1 is a simple way of illustrating the function of post-tensioned anchors.

At elevation 1038’ there exists a 1”-3” thick horizontal mud seam. It was encountered during the excavation beneath monolith #8 and extends east to monolith #1 at approximately the same level (NYCBWS, 1924). As shale is the predominate rock type underlying the spillway, concerns arose after the (then) record breaking flood of January 19, 1996 regarding the ability of the structure to maintain its stability and resist a sliding failure, should the dam be subjected to another flood of equal or greater magnitude. This apprehension led the NYCDEP to retain GZA Environmental to study the feasibility of using high capacity post-tensioned anchors, in the spillway. In this application post-tensioned anchors are used to mechanically exert downward pressure on the overflow spillway section of the dam, creating more shear resistance to sliding upon the bedrock underlying the dam’s foundation. During the eight decades of its existence, 1926-2006, prior to placement of the post-tensioned anchors, the concrete spillway was subject to extensive weathering and erosion. This is well illustrated by the accompanying pictures (NYCBWS, 1926).

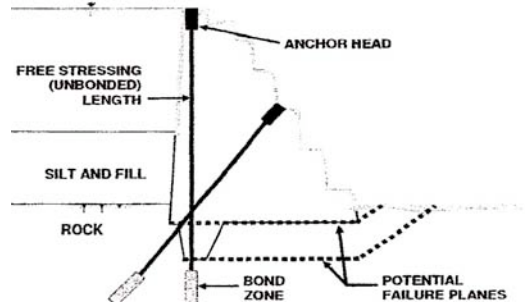

Figure 2 illustrates a typical anchor installation in the Gilboa Dam Spillway (Zicko et al. 2007).

Table 1. Anchor Groups

| Group ID | Range of Number of Strands | Design Capacity Range (kips) | Selected Number of Strands | Individual Anchor Design Capacity (kips) |
|----------|----------------------------|------------------------------|----------------------------|--|
| A | 33-39 | 1160-1371 | 39 | 1371 |
| B | 40-45 | 1406-1582 | 45 | 1582 |
| C | 46-52 | 1617-1828 | 52 | 1828 |
| D | 53-58 | 1863-2039 | 58 | 2039 |

Table 2. Summary of Minimum Design Parameters

| Number of Strands | Design Load (kips) | Drill Hole Diameter (inch) | | Sheathing Diameter (inch) | | Bond Length (ft) | |
|-------------------|--------------------|----------------------------|----|---------------------------|----|------------------|----|
| | | 12 | 15 | 8 | 10 | 31 | 41 |
| 39 | 1371 | 12 | 15 | 8 | 10 | 31 | 41 |
| 45 | 1582 | 12 | 15 | 8 | 10 | 35 | 45 |
| 52 | 1828 | 14 | 15 | 8 | 10 | 35 | 45 |
| 58 | 2039 | 14 | 15 | 10 | 10 | 39 | 49 |

Figure 3: The dimensions and design loads of the 79 post-tensioned anchors installed thus far in the spillway are included (Zicko et al. 2007).

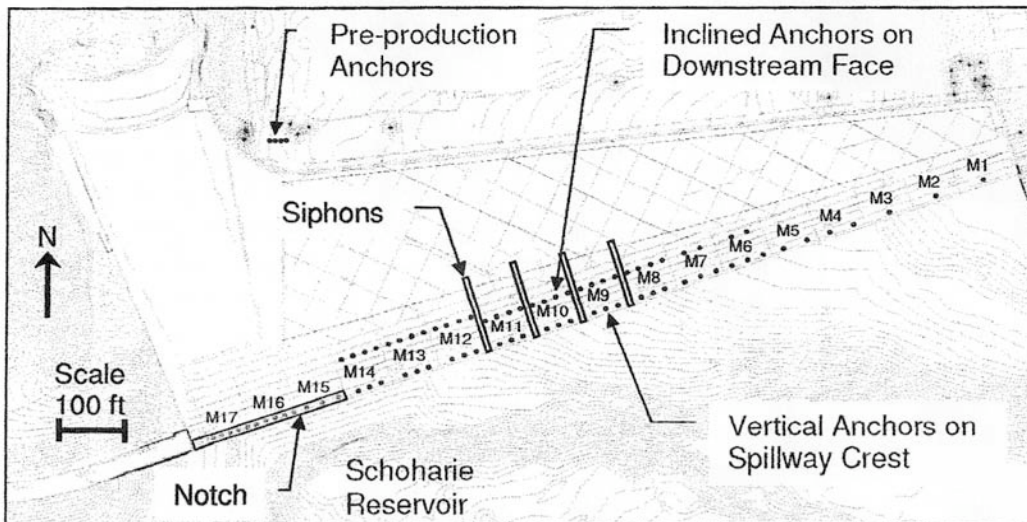

Figure 4 shows the placement of the anchors in the spillway (Zicko et al. 2007).

Monoliths 13, 14 and 15 were considered most at risk of a sliding failure prior to the placement of the anchors in 2006. To date, forty-seven vertical anchors and 32 inclined anchors have been installed through the overflow spillway section.

A primary reason for using post-tensioned anchors for dam stabilization is economy. Post-tensioned anchors are a proven and effective technique that is less costly than dam reconstruction or the replacement of the existing concrete gravity section. Post-tensioned anchors, like dams, have a finite service life. It is the assumption of NYCDEP that the Gilboa Dam and the post-tensioned anchors installed there will have a service life of 50 years (2006-2056; Zicko et al. 2007). A means of supporting this assumption is installation of two pre-production anchors equipped with load cells. The two anchors were locked-off at 70% of their guaranteed ultimate tensile strength (GUTS). Subsequent to being locked-off, these pre-production anchors, referred to as sentinel anchors, were monitored intermittently over the succeeding 18 months. Using the data obtained from the monitoring, a graph (fig 5) was prepared which indicates that the anchors will maintain approximately 91 % of their lock-off load, 50 years after their installation (Zicko et al. 2007). This is an interesting conclusion since the two pre-production sentinel anchors are not located in the overflow spillway section of the dam, rather the sentinel anchors are downstream approximately 75 yards from the Gilboa Dam. These anchors were placed in bedrock not subject to the seepage conditions immediately below the dam and are of smaller diameter with fewer tensioned strands than those installed in the overflow spillway section. In addition, they are not subjected to the strains that the anchors in the dam are. Specifically, forces absent from the sentinel anchors, but which are having an impact of the service life of the Gilboa Dam anchors are: uplift, flood loading pressures, ice pressures, and temperature changes as they relate to environmental and seasonal fluctuations. The overflow spillway section does expand and contract relative to the temperature of air and water (FERC, rev. 2002, ch. 3).

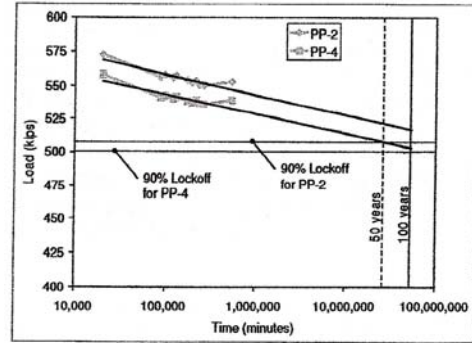

Figure 5

Zicko et al. (2007) stated “Prior to the proposed reconstruction of Gilboa Dam in upstate New York, 79 very high capacity rock anchors were installed from the dam crest and downstream face to improve the interim stability of the dam. Given concerns over potentially compromising corrosion protection at the head, and other logistical reasons, it was elected not to install load cells in the permanent anchors. In order to satisfy potential concerns regarding the long-term performance of the anchors, many of which were installed in argillaceous rocks of variable properties, several “defenses” were put in place. These included a conservative design process; preproduction pull-out tests; the concept of off-site “sentinel” anchors (with load cells); stringent installation and testing procedures; and Performance Testing (i.e., progressive cyclic) on every anchor (not just on a limited number; Zicko et al. 2007).

Regarding dam stability, in the Federal Energy Regulatory Commission’s book, “Gravity Dams”, it states on pg. 1, ch. III, “Conservative assumptions can reduce the amount of exploration and testing required. For example, if no cohesion or drain effectiveness were assumed in an analysis, there would be no need to justify those assumptions with testing. For this reason, it may sometimes be more reasonable to analyze a dam with conservative assumptions. There is, however, a minimum of knowledge of the foundation that must be obtained. The potential for sliding failure of the dam foundation is generally investigated”(FERC, rev. 2002, ch. 3). It is the contention of Dam Concerned Citizens, Inc. (DCC, Inc) that under the state of emergency that was declared at the Gilboa Dam in October 2005, that an inadequate amount of time and attention was devoted to the study of the bedrock and that insufficient instrumentation was placed in the spillway at the time of the

post-tensioned anchor installations. This statement is based on the fact that the four extensometers in the Gilboa Dam spillway failed to work after 12:04 pm, August 28, 2011. This led to the declaration of a Code Orange or Type B emergency. All video and data communication from the Gilboa Dam was lost shortly after the extensometers failed (DeJohn et al. 2011).

On page 2 of the Zicko et al. (2007) document, it states under the heading of Geotechnical Investigation, "The schedule for interim improvements did not permit the completion of a full-scale geotechnical investigation prior to the selection of the shear strength parameters for use in rock anchor design" (Zicko et al. 2007). This is in direct contradiction to the FERC recommendations regarding the geotechnical investigation of dam foundation properties. On page 30 of the FERC book, "Gravity Dams" it states "Sliding failure may result when the rock foundation contains discontinuities and/or when they contain clay, bentonite, or other similar substances, and when they are adversely oriented. Appropriate foundation investigation and exploration must be done to identify potential adverse features" (FERC, rev. 2002, ch 3). It is well to remember the presence of the mud seam at elevation 1038' beneath the dam spillway when considering these FERC guidelines.

This paper presents a comparison of FERC recommendations and requirements for the instrumentation of dams under their jurisdiction so that what are considered reasonable safety measures by that federal agency can be examined in the context of those required by the New York State Department of Environmental Conservation (NYSDEC) regarding dams under their jurisdiction. The Gilboa Dam/Schoharie Reservoir currently operates under NYSDEC not FERC regulations. The table in (fig. 6) describes the minimum recommended instrumentation for existing dams under FERC regulations (FERC-app IX-A). Upon a review of Part 673 Dam Safety Regulations, NYSDEC, there are no requirements for instrumentation of dams under its jurisdiction.

The FERC policy, "9-4.2.2.6 Loads in Post-Tensioned Anchors" regarding the instrument monitoring of post-tensioned anchors reads, "Loads should be monitored in post-tensioned anchors that are required to meet stability

criteria. The number of anchors to be monitored should be evaluated on a case-by-case basis, but should typically be between 5 and 10 percent of the total number of anchors. All existing post-tensioned anchor installations that do not have provisions to measure loads in representative anchors should be modified, wherever possible, to have such provisions. Existing post-tensioned anchors that cannot be modified to measure loads should be evaluated on a case-by-case basis. The possibility of loss of load from corrosion, creep of the grouted anchorage, and movements that may have locally yielded the anchor should be evaluated" (FERC, app. IX).

The fact the Gilboa Dam spillway was able to sustain both the record overflow of el 1337.97'(DeJohn et al. 2011) and a maximum estimated spillage of 119,336 cfs (NYPA, 2011) is probably attributable to the presence of the 79 post-tensioned anchors that were installed in 2006. The effects of the record flood upon those anchors are unknown due to the absence of load cells.

Regarding the stability of structures like the Gilboa Dam, FERC states in "9-3.3.1 Engineering Concepts-All structures move as the result of applied loads. Embankments settle and spread over time as the result of consolidation and secondary settlement of the dam and foundation from self-weight. Embankments also deform due to external loads produced by reservoir water, rapid drawdown, earthquakes, undermining, swelling clays, and piping. Concrete structures deform due to internal loads such as pore pressure, cooling, and alkali aggregate reactions of concrete; and external loads caused by air and reservoir temperature, solar radiation, reservoir levels, uplift pressure, wind, earthquakes, undermining, ice, overflowing water, swelling clay, and foundation settlement. Movement in response to such loads are normal and acceptable, providing they are within tolerable ranges and do not cause structural distress. Embankments are less brittle than concrete structures and can undergo larger movements without distress. As a result, measurements of surface movements of embankment dams are typically less precise than those for concrete structures. Sudden or unexpected direction, magnitude, or trend of surface movement could indicate developing problems. Internal movement measurements of both concrete and embankment dams and their

foundations should be detailed and precise (FERC, app IX-A).

Do post-tensioned anchors ever fail before their rated service life has expired? An article in "HydroWorld.com" by Malte O. Cederstrom, "Dam Safety, Investigating Failures of Post-Tensioned Anchors" describes the failure of 7 of the 78 anchors installed at the ALVKARLEBY Dam near Stockholm, Sweden. The 5th largest hydroelectric dam (in terms of production) in Europe and the largest in Sweden is of similar age and construction to the Gilboa Dam, built in early 20th century, of concrete monoliths cast in widths of 10-15 meters. A team of design engineers, the manufacturer, the installer, and lab specialists, researching chemical and metallurgical analysis, conducted the lengthy investigation into the failure of the anchors. Researchers concluded that the probable causes of failure included an overload, such as high water levels, stress-induced corrosion combined with high degree of brittleness of the steel, and inadequate corrosion protection provided by the plastic caps installed on the anchors to keep grease in and water out. The results led to the installation of a different type of anchor in the entire facility negating the necessity to rely on the remaining anchors (Cederstrom, 2012). It is presumed that the steel used in these post-tensioned anchors was of Swedish origin and made in an electric furnace. "Electric steel" has lower sulfur content and is less subject to corrosion than steel made using coal or coke as the source of heat. The anchor cables or tendons used at Gilboa are of Chinese manufacture. How the metal in the cables was made is unknown. A team of dam safety engineers agreed that installing new anchors in strengthened concrete was the most economical and the best way to stabilize the Alvkarleby dam. Inspectors suggested that to strengthen the concrete portion of the dam, grout be injected into holes drilled 1-meter apart the entire length of the dam and core samples taken when the anchors were installed showed that the injected grout had greatly improved the strength of the concrete. The new anchors, 40 steel tendons, each consisting of twelve, 12-millimeter-diameter strands, were split apart in the lowest 5 meters to improve anchoring. Above the anchor zone, the wires were coated in protective grease and placed inside plastic pipes that would allow the wire to move freely when tensioned. The anchor holes

above the bond zone were then filled with grout. After the grout had cured, the anchors were tensioned to 1,500 kiloNewtons. The anchors have an expected life of 50 years and a sample testing will be performed every 5 years (Cederstrom, 2012).

Based upon the experience at the Alvkarleby dam, three conclusions can be made: (1) Given the argillaceous composition of the rock underlying the Gilboa Dam spillway, load cells should accompany new post-tensioned anchors placed in the Gilboa Dam spillway thus eliminating uncertainty regarding the long-term performance of the PT-anchors. The number of and placement of the new anchors with load cells should be determined by adherence to FERC guidelines. (2) NYCDEP, while not currently subject to FERC oversight at Gilboa, NY, should voluntarily adopt FERC policies regarding the minimum instrumentation required in a dam. The adoption of these time proven, reasonable and achievable standards would do much to increase the safety of the public, living downstream of the Gilboa Dam, should the stability of the Gilboa Dam spillway ever come into question, as it did after the flood of January 19, 1996. (3) The location and number of instruments installed in the Gilboa Dam as a complete entity, 1324' overflow spillway section and 700'+0'- non-overflow embankment section should follow FERC guideline 9-5.5. "Minimum instrumentation should be installed where behavior is expected to be representative of the dam as a whole. The number of instruments should be sufficient to provide a complete picture of the parameter being measured. Usually, minimum instrumentation should be installed along longitudinal or transverse sections of the dam. Often, depending on access and equipment costs, it may be more cost-effective to install redundant instruments to account for the possibility of malfunction, rather than performing a replacement of inoperable instruments at a later date. For example, vibrating-wire piezometers transducers are relatively inexpensive and are often installed in pairs to provide continuity of data if one of the transducers should fail. If a sensor will be inaccessible for calibration or replacement, multiple sensors should be considered to improve redundancy. Redundant measurements are also useful for verifying and evaluating unusual readings" (FERC, app IX-A).

MINIMUM RECOMMENDED INSTRUMENTATION FOR EXISTING DAMS ¹

| TYPE OF MEASUREMENT | LOW-HAZARD POTENTIAL DAMS — ALL TYPES | SIGNIFICANT AND HIGH HAZARD POTENTIAL DAMS | | | | | |
|--|---------------------------------------|--|------------------|------|----------|----------------------------------|---------------------|
| | | EMBANKMENT | CONCRETE GRAVITY | ARCH | BUTTRESS | SEPARATE SPILLWAY AND/OR ORIFICE | INTEGRAL POWERHOUSE |
| VISUAL OBSERVATION ² | X | X | X | X | X | X | X |
| RESERVOIR LEVEL | | X | X | X | X | X | X |
| TAILWATER LEVEL | | X | X | X | X | X | X |
| DRAIN FLOW, SEEPAGE, AND LEAKAGE | | X | X | X | X | X | X |
| POREWATER PRESSURE ³ | | X | X | | | X | X |
| SURFACE SETTLEMENT | | | | | | | |
| SURFACE ALIGNMENT | | | X | X | X | X | X |
| INTERNAL MOVEMENT | | | | | | | |
| JOINT/CRACK ⁴ DISPLACEMENT | | | X | X | X | X | X |
| FOUNDATION MOVEMENT ⁵ | | X | X | X | X | X | X |
| SEISMIC LOADS ⁶ | | X | X | X | X | X | X |
| LOADS IN POST-TENSIONED ANCHORS ⁷ | | | X | X | X | X | X |

Figure 6

References

- Cederstrom, M.O., "Dam Safety, Investigating Failures of Post-Tensioned Anchors," HydroWorld.com, 2005, p. 1-3.
- DeJohn, T., Holderbaum, R., and Kline, R., "EAP Post Incident Report Form and Supplemental Report of the Gilboa Dam," NYCDEP, 2011.
- FERC, "Examples of Minimum Instrumentation, App. IX-A," p. 9-21 and 31.
- FERC, "Gravity Dams", 2002, ch. III, p. 3-1 and 3-14.
- New York City Board of Water Supply-18th Annual Report, 1924, p. 83.
- New York City Board of Water Supply-20th Annual Report, 1926, p. 55.
- New York Power Authority, "FERC Section 12.10 Report for the Emergency Action Plan Type B Emergency at the Blenheim Gilboa Pumped Storage Power Project, FERC LP 2685-NY," 2011, p. 10, unpublished.
- Zicko, K.E., Bruce, D.A., Kline, R.A., "The Stabilization of Gilboa Dam, New York, Using High Capacity Rock Anchors: Addressing Service Performance issues," 2007, p. 1-8.

STREAM GAGES ON SCHOHARIE CREEK AND ITS TRIBUTARIES

Sherrie Bartholomew¹, Howard R. Bartholomew¹ and Alexander Bartholomew²

¹Board Members of Dam Concerned Citizens, Inc., PO Box 310, Middleburgh, NY

²SUNY New Paltz, 1 Hawk Drive, New Paltz, NY

Dam Concerned Citizens, Inc., a citizen advocacy group, is currently focusing on issues directly related to the renovation of the Gilboa Dam, a project that will be on going until 2017. Since its creation in 2005, the paramount concern of DCC has been the rehabilitation of the Gilboa Dam and all appurtenant infrastructure to the highest possible factor of safety. DCC's board of directors, composed of Schoharie, Montgomery and Schenectady County residents, living below the Gilboa Dam, are advocates for the public before local, state and federal government.

As adequate instrumentation built into the structure of the dam is an essential component in determining its safety, so too is adequate instrumentation measuring stream flow, elevation and volume a necessary part of public safety and protection from flooding. DCC, Inc. is calling for NYCDEP to resume funding for the USGS stream gages they ceased underwriting in 2009 on the Bataviakill and other tributaries of the Schoharie Creek. Hurricane Irene and Tropical Storm Lee illustrated the need for more USGS stream gages, than exist at present both, above and below the Gilboa Dam/Schoharie Reservoir.

RETHINKING FORECASTED IMPACTS OF GRADUAL CLIMATE CHANGE IN THE MOHAWK WATERSHED AND OTHER NORTHEASTERN WATERSHEDS: EXTREME EVENTS VERSUS GRADUAL CHANGE

Jaclyn Cockburn¹ and John I. Garver²

¹Geography Department, University of Guelph, Guelph ON; ²Geology Department, Union College, Schenectady, NY

Landscape evolution models predict that moderate (or average) events do the most work on a landscape over time, given that they are the most frequent (Wolman and Miller, 1960). Temporal and spatial scale contexts are key to these interpretations. In the Mohawk Watershed we have seen that on shorter time scales events larger-than-normal can do considerable damage (e.g. August 2011). Without a doubt these larger-than-normal events have an immediate impact on the landscape, the river function and adjacent infrastructure and suggest that we need to retool landscape evolution models to fit our needs with respect to near-term changes in the landscape. In most climate change impact assessments, the predictions or forecasts indicate trends toward warmer seasons, wetter winters, potential water shortages in summers (Rosenzweig, et al., 2011). These findings primarily come from Global Climate Models (GCMs) that use varying greenhouse gas emission scenarios to produce climate variable outputs for sometime in the future. These models, complex and intricate, certainly aid in our understanding of the impact changes in atmospheric conditions can have on our near future climate. Many policy decisions and planning challenges are based on the outputs and interpretations of these models. However, GCM outputs are difficult to downscale (both temporally and spatially) and are better suited to predicting trends, rather than forecasting extremes. Are trends and moderate change priorities for watershed management and science, or rather should we focus on extremes and potential changes they may bring? In this study we present USGS discharge and suspended sediment data to evaluate landscape denudation rates over the 20th and early 21st century. We propose that given the apparent increase in extreme events, problems and issues surrounding these scenarios should be the priority for planning and management. Irene and Lee were both large runoff events (Figure 1), but both generated significantly different responses with respect to suspended sediment yield (Figure 2) although part of this difference was due to the spatial variation in precipitation maxima.

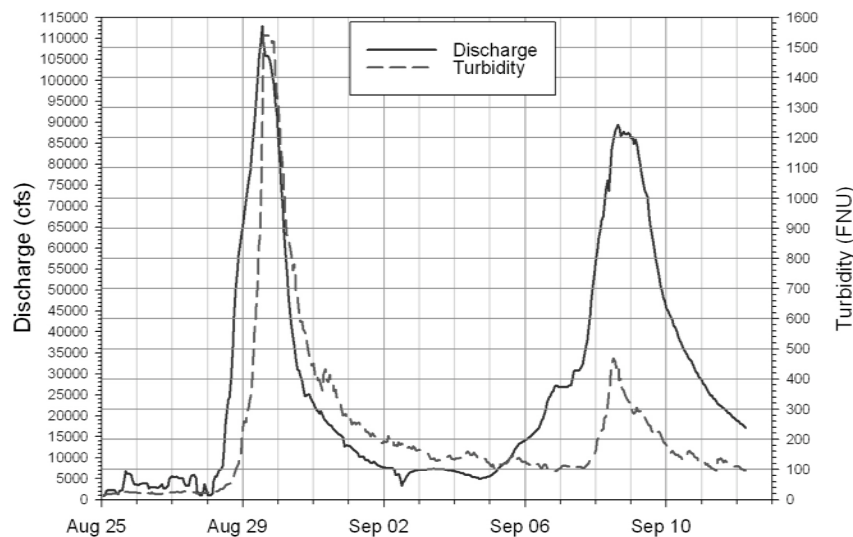

Figure 1: Hourly discharge and turbidity measured on the Mohawk River at Cohoes, NY during Irene and Lee in late summer 2011 (data from USGS).

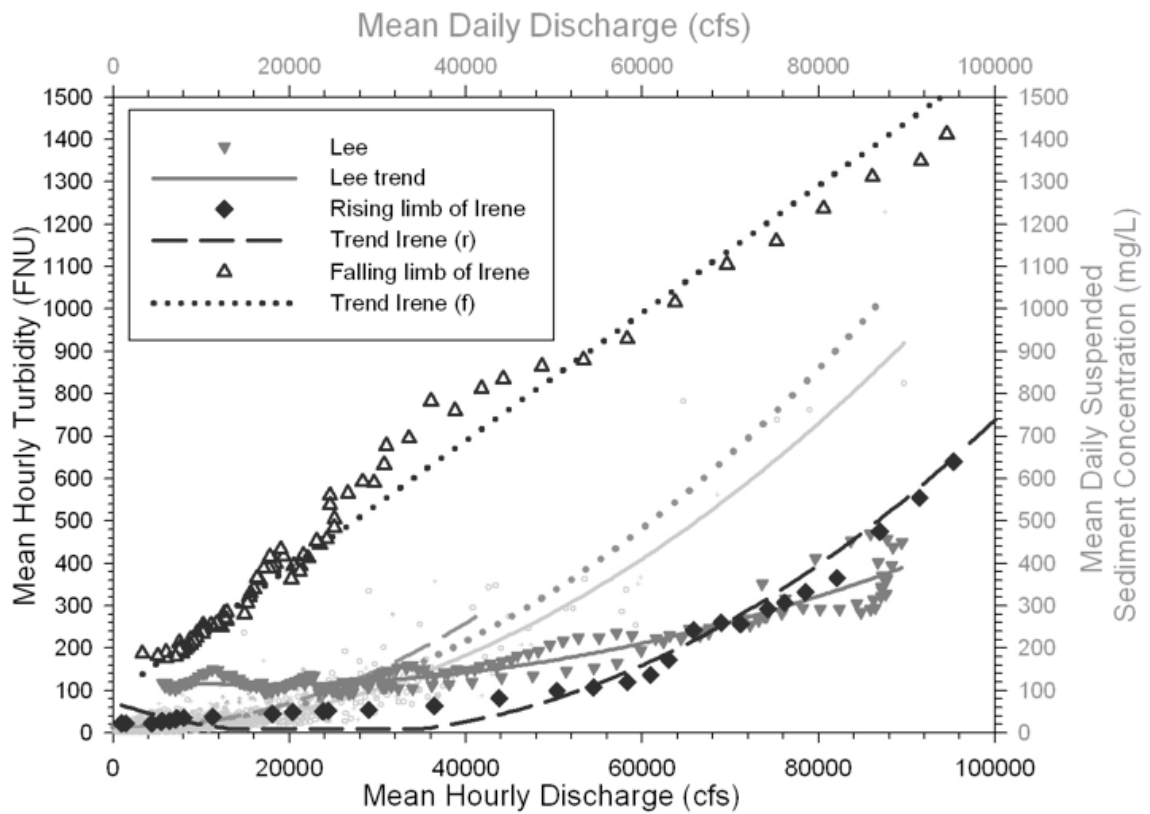

Figure 2: Mean hourly discharge and turbidity in the Mohawk River measured at Cohoes, NY during Irene and Lee. Light gray (background) points represent the daily values over the periods between 1954-57 and 2004-07.

Rosenzweig, C., Solecki, W., DeGaetano, A., O'Grady, M., Hassol, S., Grabhorn, P. (Eds.). 2011. Responding to Climate Change in New York State: The ClimAID Integrated Assessment for Effective Climate Change Adaptation. Technical Report. New York State Energy Research and Development Authority (NYSERDA), Albany, New York.

Wolman, M.G., Miller, J.P. 1960. Magnitude and frequency of forces in geomorphic processes. *Journal of Geology*, 68: 54-75.

MONITORING SMALL-SCALE BEDLOAD TRANSPORT USING PASSIVE INTEGRATED TRANSPONDERS (PIT)

Garnet Cornell and Dylan Gillingham

Geography Department, University of Guelph, Guelph, ON Canada

There has been limited success in attempting to monitor bedload transport within a channel. Previous research interested in tracking particles via radio frequency identification technology (RFID) has done so with relatively large particles ($d_{50} > 10$ cm). In this study, various artificial sand particles were constructed of differing sizes and densities. The objective of this research is to closely mimic the hydrologic characteristics of typical bedforms in rivers with varying sediment sources (e.g., glacial till, reworked fluvial material, colluvial deposits, woody debris). The artificial bedload unit contains a Passive Integrated Transponder (PIT), allowing its movement to be tracked in future studies. This work focuses on emulating the displacement of a sand dune within a fixed flow velocity. This study will provide an alternative approach to studying bedload transport in a fluvial channel that is cost effective and accurate.

Known techniques used for tracking individual sediment particles along a fluvial channel include painted particles, passive magnetic tracers, and battery operated radio-tracking technology (Lamarre et al. 2005; Allen et al. 2006; Bertoni et al. 2010). Painted particles are typically coloured to classify their morphological features, such as shape, size, and density. The painted particles method is relatively inexpensive and a large quantity of particles can be tested at once. However, abrasion of the painted surface and low recovery rates limit the application of this technique (Lamarre et al. 2005). Passive magnetic tracers involve the implantation of a magnetic core or rely on the use of the natural magnetic characteristic of a particle. Recovery rates are high when combined with the use of a magnetometer. The limitations of this method were that individual particles could not be identified after particle movement and resulting data can be skewed by naturally occurring magnetic materials in the fluvial channel (Lamarre et al. 2005). Battery operated radio-tracking technology (active transponders), provides an accurate measurement of individual particles along the bed, however the use of batteries limit the transmitter lifespan (Lamarre et al. 2005). Each transmitter is equipped with a unique frequency, which allows for each particle to be tracked separately (Lamarre et al. 2005). Furthermore, the batteries in these transmitters control the size and can increase or decrease the density of the artificial unit used in the study.

The PIT tags to be used in this study have tremendous potential and are thought to be the most suitable method of tracing particle movement over a long period of time; due to their lack of a battery source (Nichols, 2004). This battery-free technology (passive technology), allows for the transponders to be relatively small, and as such, used for studies focusing on smaller particles. In addition, the life span of these implanted transponders increases from 1-2 years, (active transponders), to 50 years if no battery is required (passive) (Allan et al. 2006). Traditionally, PIT tags have been implemented in the field to track cobble sized sediment over several years along a beach coast (Allan et al. 2006). They have also been used in fluvial settings such as gravel-bedded rivers (Lamarre et al. 2005). In each of these studies, it was decided to avoid generating artificial particles, as there was concern about the impacts on the hydrodynamics of the artificial unit. In this study, we evaluated the artificial units' hydrodynamics using an Acoustic Doppler Velocimeter to determine the turbulence around these particles and justify the use of artificial material as tracers.

The work presented here represents some of the first attempts to manufacture a 'field-ready' method of monitoring smaller bedload transport and may potentially aid in observing variable source-area runoff. Future plans include setting particles in the field to monitor their performance. As well, on-going work is attempting to design a logging detection antenna that can be left in the field.

Allen, J. C., Hart, R., Tranquili, V. (2006). *Marine Geology*. 232. 63-86.

Bertoni, D., Giovanni, S., Benelli, G., Pozzebon, A., Rausedo, G. (2010). *Sedimentary Geology*. 228. 140-150.

Lamarre, H., Mac Vicar, B., & Roy, A. (2005). *Journal of Sedimentary Research*. 75. 736-741.

Nichols, M. H. (2004). *Applied Engineering in Agriculture*. 20 (6). 783- 787.

THE SEDIMENTARY RECORD OF MOHAWK RIVER FLOODS PRESERVED IN COLLINS POND, SCOTIA, NY CONFIRMED BY HURRICANE IRENE

John Farrell and Donald Rodbell

Geology Department, Union College, Schenectady, NY 12308 U.S.A.

Collin's Pond (42°50'N; 73°57'W; 64 m asl) is a small (0.25 km²), shallow ($z_{\max}=8.5$ m), eutrophic pond on the floodplain of the Mohawk River near Scotia, New York. The small drainage basin of Collin's Pond is similar in size to the lake itself, yet Collin's Pond has accumulated sediment at a high rate (~ 7 mm yr⁻¹ for the last 1000 years). The bedrock underlying the Mohawk River drainage basin varies considerably: the northern part of the drainage basin is underlain mainly by gneiss, the central part by calcareous shale and dolostone, and the southern part by carbonates and Paleozoic red beds of the Catskill Mountains. An ~ 7.5 -meter-long sediment core from Collins Pond reveals numerous discrete laminae 0.1-10 cm thick of pink-colored sediment with a mineral magnetic signature similar to that of modern alluvium derived from the Paleozoic red beds of the Catskill region. The red-color intensity of the sediment core was measured continuously with sub-millimeter resolution revealing dozens of probable flood events over the past millennium, many of which correlate with Hurricane landings in the mid Atlantic and New England states. Flood waters of the Mohawk River in response to Hurricane Irene on 29-30 August, 2011 were principally derived from the Catskill region and inundated Collins Pond depositing a layer of pink sediment 0.2-0.5 cm thick throughout the lake basin. Laminae from flood events were sampled and treated to remove organic matter and biogenic silica, and analyzed with a Coulter LS 230 laser diffraction grain size analyzer. Results indicate that flood laminae are composed of fine silt (4-10 μm) that are slightly coarser than background sediment, and in most cases laminae are normally graded suggesting sediment delivery via overflows as opposed to density driven undercurrents.

CHANGE IN THE MOHAWK WATERSHED AND VULNERABILITY TO INFRASTRUCTURE

John I. Garver¹ and Jaelyn Cockburn²

¹Geology Department, Union College, Schenectady NY

²Geography Department, University of Guelph, Guelph, ON

Recent flooding in the Mohawk watershed should be evaluated in the context of a changing and dynamic hydrologic system (Garver and Cockburn, 2011). Climate and hydrologic data suggest that important changes have occurred in NY State in the past few decades and it is important to understand what these changes mean in different sectors of the State (Figure 1; Hayhoe, et al., 2006; Frumhoff et al., 2007).

The 2012 IPCC report that focuses on managing risks of extreme events advocates approaching change and hazard reduction at a local level. They note that: “Data on disasters and disaster risk reduction are lacking at the local level, which can constrain improvements in local vulnerability reduction. There are few examples of national disaster risk management systems and associated risk management measures explicitly integrating knowledge of and uncertainties in projected changes in exposure, vulnerability, and climate extremes” (IPCC, 2012).

The recently released ClimAid study (Rosenzweig et al., 2011) notes that the annual average precipitation in NY State has been increasing by nearly 1 cm per decade since 1900 and there has been an increase in the frequency of heavy rainfall that is especially pronounced in the Northeast (Shaw et al., 2011; see also DeGaetano, 2009; USGRCP, 2009). The first part of this conclusion is misleading because it ignores the longer precipitation records in NY State. For Albany, the early 1900’s were a long-term low in a nearly 190-year precipitation record, but despite this variation in the long-term trend (see Figure 2), the recent decade has been the wettest on record. Instrumental records show that the distribution of precipitation in the last few decades has not been uniform (Figure 2). Thus, a key to future flood mitigation and watershed management is to recognize variation in the regional distribution of these changes in precipitation, and the relative intensity of precipitation because this change has not been uniform across the State.

The geography of the Mohawk basin is uniquely positioned to reveal changes in the hydrologic

regime in this part of the Northeast because the Mohawk River is fed by two primary tributaries: the West Canada Creek drains part of the Adirondacks and the Schoharie Creek drains part of the Catskill Mountains. Hence the hydrology of the basin is sensitive to changes in continental-tracking atmospheric systems (captured mainly in the West Canada Creek basin) as well as Atlantic coastal systems (captured mainly in the Schoharie Creek basin). This is the only basin in NY State that has this unique geographical position.

Our reading of the hydrologic record of rivers in the Mohawk watershed suggests that the most significant change has been in the last thirty years and much of this change can be attributed to an increase in the amount of precipitation and the frequency of extreme precipitation events in the Catskill Mountains (Frei et al., 2002; Burns et al., 2007; Garver and Cockburn, 2011). Changes in the record are subtle, but important. Climate models show that projected changes in mean annual precipitation for the Catskills range from an increase of ~10% to a decrease of 30% by the latter part of this century (Frei et al., 2002): thus our conclusion is that climate modeling in its current form is not likely to be helpful for guiding near-term management decisions.

The recent period of high discharge on the Mohawk corresponds to the wettest decade on record at Albany according to NOAA records and these records extend back to the early nineteenth century (Figure 4). Discharge records collected by the U.S. Geological Survey show that the relative flow from the Schoharie has increased relative to the West Canada Creek since 1996 (Garver and Cockburn, 2011). This change could reflect greater precipitation in the southern part of the basin, decrease precipitation in the northern part of the basin, or both. Regional precipitation records show that the change can be largely attributed to an increase in precipitation in the Catskills and along the Atlantic seaboard (Burns et al., 2007; see Figure 1).

The abundance of water in the Schoharie Creek presents a considerable management challenge partly because much of this water appears to be associated with high discharge events, many of which have caused significant flooding that is locally chronic. The Irene and Lee events of 2011 were one example of this new emerging extreme situation, and it needs to be emphasized that a major increase in water in this basin was recognized prior to flooding of Irene and Lee (i.e. Garver and Cockburn, 2011).

Recent work has shown that regionally there has been an increase in the number of heavy and very heavy precipitation events (Groisman et al., 2004; DeGaetano, 2009), and the number of cyclonic systems in the North Atlantic has increased in size and number over the last 25 yr, but this data set consists of small numbers (Webster et al., 2005; Changnon, 2008). Thus it has been suggested that the most dramatic and significant change in the hydrology in the Mohawk watershed is related to Atlantic-tracking storms, which have had a significant effect on flooding in the southernmost part of the watershed (Garver and Cockburn, 2011).

One of the most important implications of this situation is that the recent floods in the Mohawk Watershed may be part of an emerging trend of increased water and sediment mobility in the system (Cockburn et al., 2009). If so, there are serious implications for the ability of the system to handle this water including an aging

infrastructure that is underfit for this new hydrologic regime. Examples of infrastructure vulnerability include bridges, dams, stormwater and sewer outfall systems that in many cases are more than 50 yr old. Some of these structures are crucial to the State as they include water supply for NY City (Gilboa Dam) and other local municipalities, hydropower generation (Blenheim Pump Storage), and major transportation arteries including I-90 and rail lines that are key connections in the Eastern Corridor: all of which were damaged or impaired in the recent Irene/Lee events and will continue to be vulnerable in future events.

It is unlikely that we can engineer our way out of this situation without using cost-prohibitive strategies, but instead we should focus on innovation and smart design. We have dams, and locks in many places in the watershed, but none are used for flood mitigation, this should change. It might be a good time to reevaluate flood mitigation strategies in the basin, especially in the Catskill-draining rivers, like the Schoharie Creek. We will not be able to prevent flooding in the Mohawk watershed and instead we have to be clever as to how we live with this changing natural hazard. This will include gradually clearing predicted floodways and using engineering solutions that anticipate more frequent extreme events.

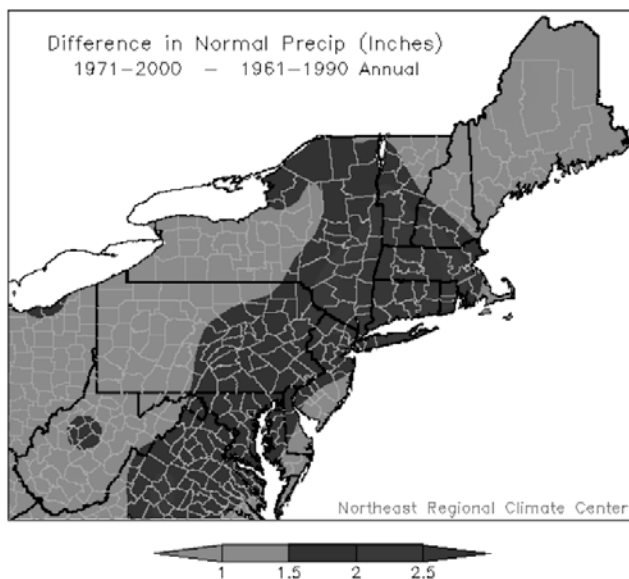

FIGURE 1: Increase in NE precipitation (Northeast Regional Climate Center). Increase in precipitation is indicated by the shift in the new normals (30 year averages used for understanding daily weather variations) established by the National Weather Service. This maps shows the increase in annual precipitation in eastern NY (and Mass / CT) up to 2.5 inches annually in the normal period from 1961 to 1990 and then between 1971-2000. This difference is largely due to a decrease in the early part and an increase in the later part of the record. Note that in areas with high relief and high topography (i.e. Catskills), floodwaters can be especially damaging because rivers in these settings tend lack significant flood plans. The new normals released in 2011 (1981-2010) have not yet been integrated into this analysis.

Floods on the Mohawk River (Schenectady)

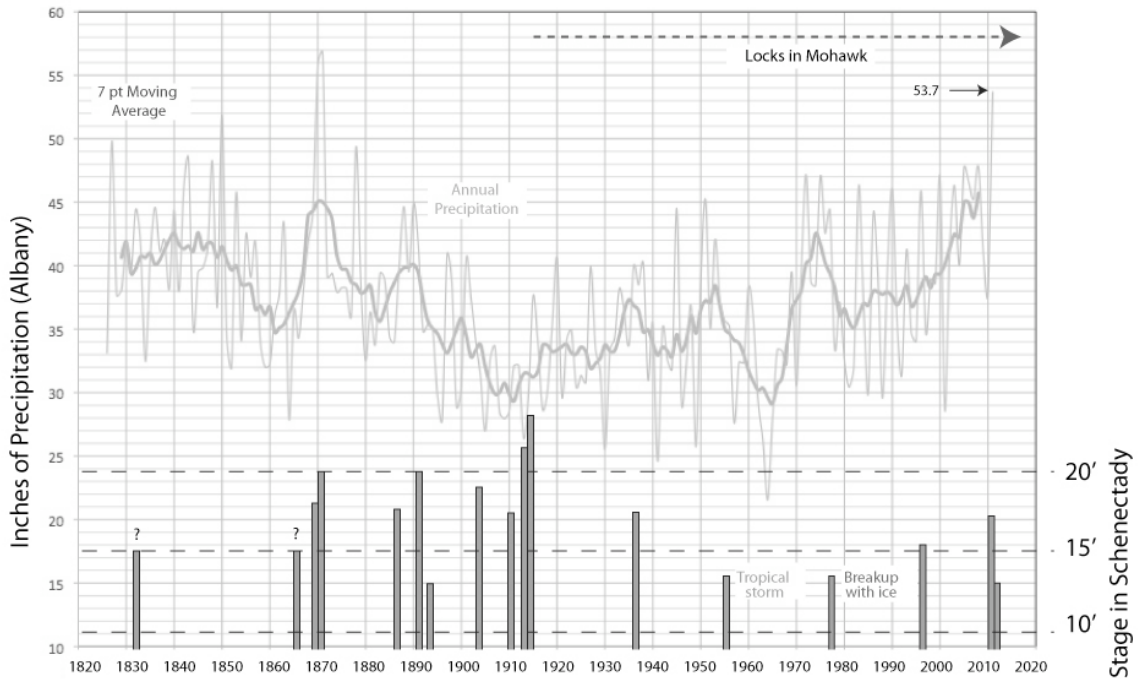

FIGURE 2: Major Floods on the Mohawk River. The flood history for the Schoharie Creek, which drains the Catskill Mountains, is partly revealed through discharge records from the U.S.G.S. gauge at Burtonsville NY, which is near the confluence of the Schoharie Creek and the Mohawk River. The tempo and rhythm of flooding has changed dramatically since 1980 (Precipitation data from NOAA/NWS, Albany station. Data for stage elevations of Mohawk flood waters in Schenectady from Garver unpublished, Johnston and Garver, 2001, and Scheller et al., 2008 and references therein).

All floods on Schoharie >10 k cfs (Burtonsville)

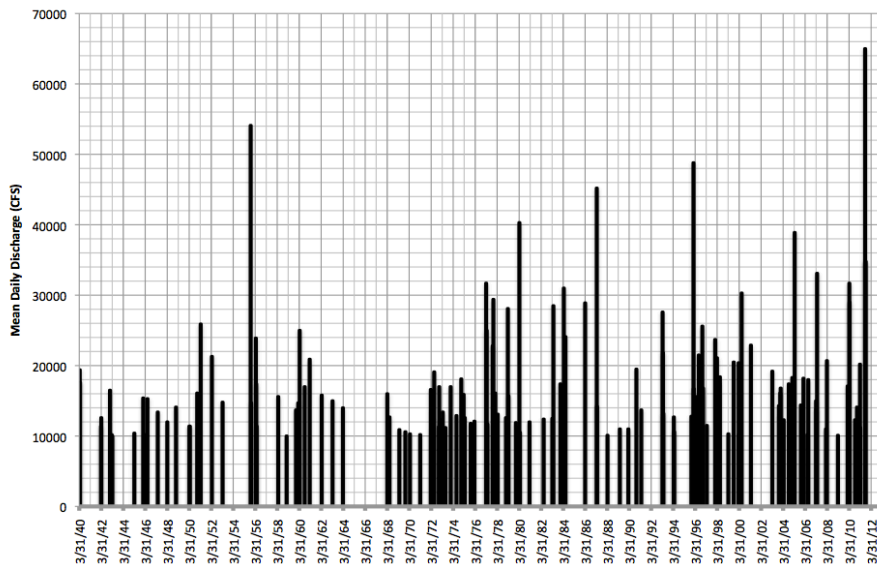

FIGURE 3: Floods on the Schoharie (larger than 10 k cfs at Burtonsville). The flood history for the Schoharie Creek, which drains the Catskill Mountains, is partly revealed through discharge records from the U.S.G.S. gauge at Burtonsville NY, which is near the confluence of the Schoharie Creek and the Mohawk River. The tempo and rhythm of flooding has changed dramatically since 1980.

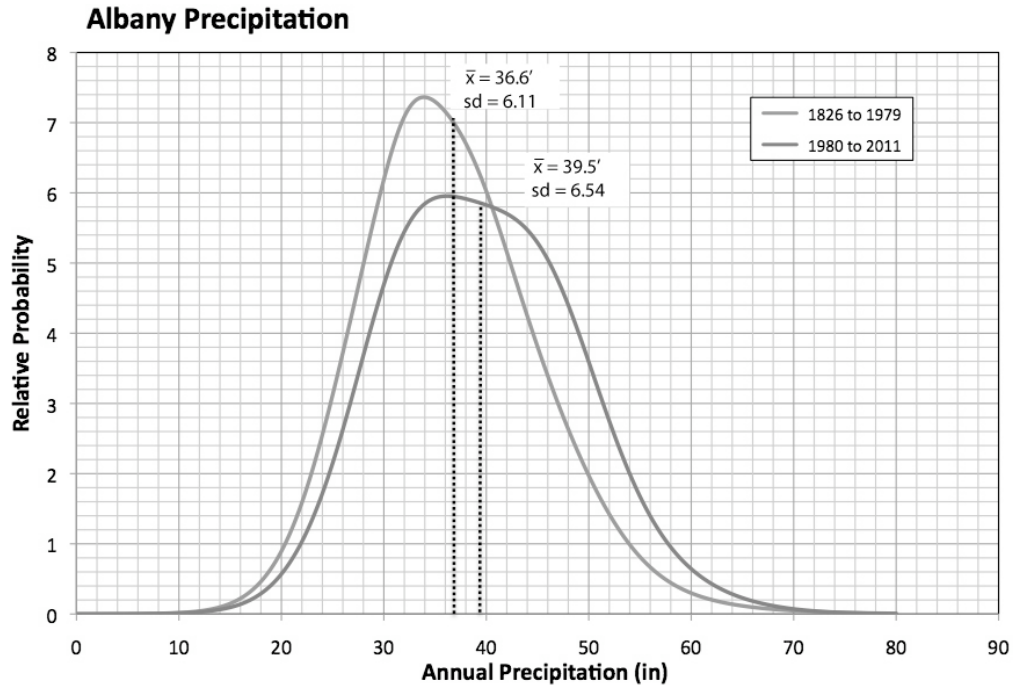

FIGURE 4: Change in precipitation in Albany (NY) over the entire record (1829 to 2011). Here we plot annual events summed as a probability density function for 1826 to 1979 and 1980 to 2011. One of the basic tenants of evaluation of regional change is to measure and understand subtle (or not subtle) changes in the geometric mean, and overall distribution of a number of key climate parameters. This analysis shows an increase in annual precipitation in the last several decades (data: NOAA/NWS data collected for Albany NY; estimation kernel for probability density of four).

References

Burns, D.A., J. Klaus and M.R. McHale, 2007. Recent climate trends and implications for water resources in the Catskill mountain region, New York, USA. *Journal of Hydrology* (336): 155-170.

Chang, E.K.M., and Y Fu. 2002. Interdecadal variations in Northern Hemisphere Winter storm track intensity. *Journal of Climate* 15, no. 6: 642-658.

Changnon, S.A., 2008. Characteristics of severe Atlantic hurricanes in the United States: 1949– 2006. *Natural Hazards* 48, no. 3: 329-33

Cockburn, J.M.H., Garver, J.I., and Kern, A., 2009, Current trends and future possibilities: monitoring for the future and how watershed dynamics may be affected by global climate change. In: Cockburn, J.M.H. and Garver, J.I., *Proceedings from the 2009 Mohawk Watershed Symposium*, Union College, Schenectady NY, p. 14-18.

Cockburn, J.M.H., and Garver, J.I., 2011, Evaluating discharge patterns in rivers across New England, In Cockburn, J.M.H, and Garver, J.I. (eds) *Mohawk Watershed Symposium 2011*, Union College Schenectady NY, 18 March 2011, p. 10.

DeGaetano, A. 2009. Time-dependent changes in extreme precipitation return-period amounts in the continental U.S. *Journal of Applied Meteorology and Climatology* v. 48, p. 2086-2099.

Frei, A., Armstrong, R. L., Clark, M. P., and Serreze, M. C. (2002). Catskill Mountain Water Resources: Vulnerability, Hydroclimatology, and Climate-Change Sensitivity. *Annals of the Association of American Geographers* 92, 203-224.

Frumhoff, P.C., J.J. McCarthy, J.M. Melillo, S.C. Moser, and D.J. Wuebbles, 2007, *Confronting Climate Change in the US Northeast: Science, Impacts and Solutions*. Synthesis report of the Northeast

- Climate Impacts Assessment (NECIA). Cambridge, MA: Union of Concerned Scientists (UCS).
- Garver, J.I., and Cockburn, J.M.H., 2011, Changes in the Hydrology of the Mohawk Watershed and implications for watershed management, In Cockburn, J.M.H, and Garver, J.I. (eds) Mohawk Watershed Symposium 2011, Union College Schenectady NY, 18 March 2011, p. 16-21.
- Groisman, P.Y., R.W. Knight, T.R. Karl, D.R. Easterling, B. Sun, and J. Lawrimore. 2004. Contemporary changes of the hydrological cycle over the contiguous United States: Trends. *J. Hydrometeorology*, v. 5, p. 64–85.
- Hayhoe, K., C.P. Wake, T.G. Huntington, L. Luo, M.D. Schwartz, J. Sheffield, E. Wood, B. Anderson, J. Bradbury, A. DeGaetano, T.J. Troy and D. Wolfe. 2006. Past and future changes in climate and hydrological indicators in the US Northeast. *Climate Dynamics* v. 28, n. 4: p. 381-407.
- IPCC, 2012. Managing the risks of extreme events and disasters to advance climate change adaptation: summary for Policymakers; Special report of the Intergovernmental panel on climate change. 19 p.
- Johnston, S.A., and Garver, J.I., 2001, Record of flooding on the Mohawk River from 1634 to 2000 based on historical Archives, *GSA Abstracts with Programs* v. 33, n. 1, p.73.
- Rosenzweig, C., Solecki, W., DeGaetano, A., O'Grady, M., Hassol, S., Grabhorn, P. (Eds.). 2011. Responding to Climate Change in New York State: The ClimAID Integrated Assessment for Effective Climate Change Adaptation. Technical Report. New York State Energy Research and Development Authority (NYSERDA), Albany, New York.
- Shaw, S., Schneider, R., McDonald, A., Riha, S., Tryhorn, L., Leichenko, R., Vancura, P., Frei, A., Montz, B., 2011, Scheller, M, Luey, K., and Garver, J.I., 2008. Major Floods on the Mohawk River (NY): 1832-2000, Unpublished Senior research, web address: http://minerva.union.edu/garverj/mohawk/170_yr.html
- Suro, T.P., Firda, G.D. and Szabo, C.O. 2009, Flood of June 26–29, 2006, Mohawk, Delaware, and Susquehanna River Basins, New York: U.S. Geological Survey Open-File Report 2009–1063, 354 p.
- USGRCP - U.S. Global Change Research Program. 2009. Global Climate Change Impacts in the United States. Edited by Thomas R. Karl, Jerry M. Melillo, and Thomas C. Peterson. Cambridge University Press.
- Water Resources (Ch. 4), In Rosenzweig, C., Solecki, W., DeGaetano, A., O'Grady, M., Hassol, S., Grabhorn, P. (Eds.). Responding to Climate Change in New York State: The ClimAID Integrated Assessment for Effective Climate Change Adaptation. Technical Report. New York State Energy Research and Development Authority (NYSERDA), Albany, New York. www.nyserdera.ny.gov
- Webster, P.J., Holland, G.J., Curry, J.A., and Chang, H, -R, 2005, Changes in Tropical Cyclone Number, Duration, and Intensity in a Warming Climate; *Science*, v. 309, p. 1844-1846.

HOW EXTREME WAS IRENE? A COMPARISON OF THE 2011, 1996, 1987 FLOODS ALONG THE SCHOHARIE CREEK

Chris Gazoorian

U.S. Geological Survey, New York Water Science Center

Introduction

Historic flooding on August 28-29, 2011 was the result of intense precipitation associated with tropical storm Irene in the Mohawk River basin and throughout eastern New York State. Peak streamflow at over 50 U.S. Geological Survey (USGS) streamgages exceeded previous period-of-record maximums. Seventeen of the 22 continuous-discharge streamgages within the Mohawk River basin, including all 14 within the Schoharie Creek basin, recorded new period-of-record maximums during this event. Several USGS streamgages were damaged or destroyed during the floods and three streamgages in the Schoharie Creek basin, where some of the most devastating flooding occurred, were entirely swept away. Floods, of a lesser magnitude, occurred in the Schoharie valley during October 16, 1955, April 4-5, 1987 and January 19-20, 1996 (figure 1). The three most recent floods along the Schoharie Creek (1987, 1996, and 2011) each developed in different seasons with different antecedent conditions, which define the individual character of the events.

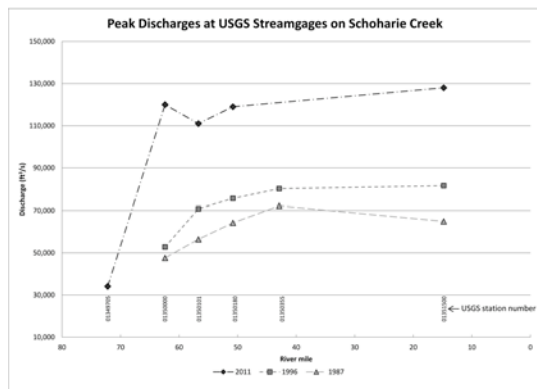

Figure 1: Peak discharges at U.S. Geological Survey streamgages on Schoharie Creek during floods of 1987, 1996 and 2011.

Schoharie Creek drains 927 mi² of the northern slopes of the Catskills. The main tributaries are West Kill, East Kill and Batavia Kill in the headwaters and Fox Creek and Cobleskill Creek in the lower reach. It flows north for 83 miles through wooded, mostly undeveloped land and passes through the Schoharie Reservoir and the Blenheim-Gilboa Reservoir to become a major tributary to the Mohawk River at Fort Hunter, NY. The Schoharie Reservoir is a New York City water supply reservoir built in 1926 and has a drainage area of 315 mi². The Blenheim-Gilboa Reservoir, 5.5 mi downstream (drainage area of 358 mi²), is a pumped-storage hydroelectric project operated by the New York Power Authority (NYPA).

The USGS New York Water Science Center deployed all available field crews during and after the August 28, 2011 flood to repair damaged gages, measure discharge and survey high-water marks to document the event and recover lost peak data. Elevations of nearly 200 high-water marks were surveyed along the entire 83-mile length of Schoharie Creek from the headwaters in Hunter, NY to the mouth near Fort Hunter, NY. Surveys were conducted at bridges, USGS streamgage locations, reservoirs, and at structures in flooded communities (figure 2). This high-water mark elevation data provide essential information to FEMA and other emergency response agencies working to rebuild communities affected by the flooding and to reconstruct a flood profile of the crest as it travelled down the Schoharie Valley. Profile data were also collected along Schoharie Creek following the floods of 1955, 1987 and 1996.

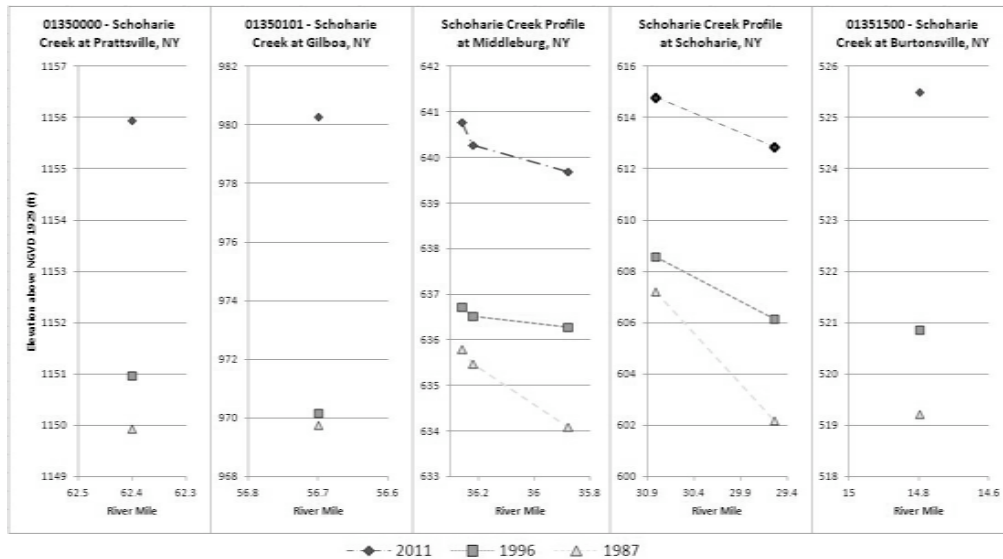

Figure 2: High-water mark elevations surveyed at selected U.S. Geological Survey streamgages and communities on Schoharie Creek following floods of 1987, 1996 and 2011.

Flood-frequency analysis of annual flood-peak discharges recorded at streamgages provides a means of estimating the probability of occurrence of a given discharge. Flood frequency is commonly expressed in terms of recurrence interval or the probability of being exceeded (one is the reciprocal of the other). What has been traditionally referred to as the 100-year flood, for example, has a 1-percent chance of being equaled or exceeded in any given year and is now referred to as the 1-percent annual chance flood. For example, the peak discharge that occurred on August 28, 2011 at the USGS streamgages Schoharie Creek at Gilboa (01350101) and Schoharie Creek at North Blenheim (01350180) have preliminary designations of 0.2-percent annual chance floods, or a recurrence interval of 500 years.

Flood of April 4-5, 1987

The flood of April 4-5, 1987 was fueled by rain from an intense coastal storm in southeastern New York State. There were over \$65 million of flood damages to homes, businesses, crops, roadways, and bridges. Perhaps most notably, a 120-foot-long New York State Thruway (Interstate 90) bridge collapsed into Schoharie Creek, killing 10 motorists. Five counties in New York were declared as major disaster areas and eligible for Federal disaster assistance. Peak discharges at several streamgages in the Schoharie Creek basin exceeded the 1-percent annual chance flood.

The Schoharie Creek basin suffered extensive losses due to as much as 9 inches of rain falling in the headwaters within the Catskill Mountains. Soils were already saturated, stream discharges were high, and some reservoirs were at or near capacity from snowmelt and previous rainfall. At the time, the 1987 flood along Schoharie Creek was one of the largest since record keeping began in the early 1900's and was exceeded only by the flood of October 1955. The Schoharie Reservoir was full and spilling before the flood began; however, less runoff in the broad, flat floodplains of the middle reach of Schoharie Creek did help to attenuate the crest of the flood as shown in figure 1 (Zembruski and Evans 1989).

Flood of January 19-20, 1996

Precipitation on January 18-20, 1996 from a strong storm system, combined with unseasonably warm temperatures, causing rapid snowmelt, resulted in extensive flooding throughout New York State. This was the most widespread and devastating flood in New York since Hurricane Agnes in June 1972. Damage to highways, bridges, and private property exceeded \$100 million (Federal Emergency Management Agency, 1997). The storm claimed 10 lives, stranded hundreds of people, destroyed or damaged thousands of homes and businesses, and closed hundreds of roads. Forty-one counties in New York were declared Federal disaster areas. The most severely affected region was within and surrounding the Catskill Mountains in southeastern New York. Ice and debris

contributed to the flooding where they became jammed at culverts, bridges, and natural constrictions within stream channels.

Record peak discharges occurred at 57 U.S. Geological Survey (USGS) streamgages throughout New York. Peak discharges at 15 streamgages equaled or exceeded the 1-percent annual chance flood. Most of these streamgages were within the Schoharie Creek and Delaware River basins. Similar to the 1987 flood, some of the most destructive flooding ensued along Schoharie Creek following more than 4.5 inches of rain falling upon at least 45 inches of melting snow in the Catskill Mountains. In the preceding month, several snowstorms struck the Catskills region each adding more than 1 – 2 feet of snow. Persistent cold weather prevented any significant snowmelt before the warm air associated with the flooding arrived. Schoharie Reservoir was nearly full prior to the flooding. Leading up to the floods, many streams had low flows resulting from minimal snowmelt and ice building-up in the channels. This flood was greater than both the 1987 flood and the 1955 flood and would remain the flood of record until tropical storm Irene flooding in 2011 (Lumia 1998)

Flood of August 28 – 29, 2011

Hurricane Irene weakened to a tropical storm as it made landfall in New York State on August 28, 2011. The storm delivered strong winds and downed many trees along coastal communities; however, the majority of precipitation associated with the storm fell in the higher elevations. Tropical storm Irene produced massive amounts of rain in the Catskill mountain region, including the Schoharie Valley. Statewide, at least 10 lives were lost and upward of \$1 billion in damages resulted from the storm (NRCC, 2011). Thousands of roads, bridges and homes were damaged or completely destroyed, including the historic, 156-year old Blenheim Covered Bridge, which had survived many previous floods. During the flooding, The New York State Department of Transportation (NYSDOT) closed all of the bridges over the Schoharie Creek from the Gilboa Dam to the Mohawk River, major parts of the New York State Thruway, and dozens of other major roads and bridges throughout eastern New York. One of the most severely affected regions was within and surrounding the Catskill Mountains in southeastern New York.

The National Weather Service (NWS) reported rainfall totals for parts of eastern New York that ranged from about 4.2 inches in Albany to over 6 inches at many locations in Columbia, Delaware, Dutchess, Schenectady, Schoharie, Ulster and Washington Counties. The Northeast Regional Climate Center reported 12.85 inches of rain in East Jewett and 10.01 inches of rain in Platte Clove, both of which lie within the headwaters of Schoharie Creek. Record breaking rainfall, combined with soils previously saturated by a wetter than average August, resulted in record flooding throughout the Schoharie Valley and many other parts of the State (NRCC, 2011).

About 50 US Geological Survey (USGS) streamgages in eastern New York recorded new period-of-record maximums as a result of tropical storm Irene. The Schoharie Creek at Prattsville, NY (0135000) and Schoharie Creek at Gilboa (01350101) streamgages, along with the East Kill near Jewett Center (01349700) streamgage, were swept away during the flood. All three sites were temporarily replaced by rapid deployment gages and had restored real-time data capabilities by September 01, 2011.

Following the storm, field crews surveyed high-water marks on streambanks, trees, structures and anywhere a distinct high-water mark elevation could be documented. This effort recovered data from USGS streamgages that did not record the peak gage heights and discharges due to damages from the storm. These surveys revealed that the Schoharie Creek changed its usual course in many locations, bypassing or submerging bridges and levees often relied upon to contain floodwaters. Seventeen indirect measurements were made to compute peak flows and extend stage-discharge rating curves at gages where previous rating curves were exceeded by the unprecedented flooding. Also, along the Schoharie Creek, nearly 200 high-water marks were surveyed to provide essential information to FEMA and other emergency response agencies working to rebuild communities affected by the flooding. This data was also useful in creating a flood profile to document the extent of flooding resultant from tropical storm Irene, and compare it to flood profile surveys on the Schoharie Creek following the 1987 and 1996 floods.

Previous peak-of-record maximums were exceeded at all 14 USGS streamgages in the Schoharie Creek basin. Perhaps most notable

was the Schoharie Creek at Prattsville, NY (01350000) station, where peak flows have been recorded since 1902, and had a peak discharge of 120,000 ft³/s. This is more than double the previous peak recorded during the January 1996 flood (figure 3). The extreme flows at Prattsville, NY reflect the large peak discharges per unit area observed at USGS stations in the headwater tributaries; such as Batavia Kill at Red Falls near Prattsville, NY (table 1.) The confluence of the main stem of Schoharie Creek and Batavia Kill occurs about 0.81 miles upstream from Prattsville, NY.

As the flood waters flowed out of Prattsville, NY they began to fill up the Schoharie Reservoir, along with Bear Kill and Manor Kill which drain directly into the reservoir. As the Schoharie Reservoir level began to peak, a large amount of water was going into storage. The Schoharie Creek at Gilboa, NY (01350101) station, just below Schoharie Reservoir, was destroyed before its flood crest occurred. Based on many high-water marks in the area, the peak stage at Gilboa, NY exceeded the previous peak, from 1996, by over 10 ft. After flowing through the NYPA lower Blenheim-Gilboa Reservoir, the flood crest travelled into the broad floodplain through Middleburg and Schoharie, NY. In many cases the open fields in this area carried as much

or more water than the channel itself. The result was significant erosion of fertile farmland soils and the destruction of crops nearly ready for harvest.

The most downstream USGS streamgauge on the Schoharie Creek is at Burtonsville, NY (01351500). The peak flow at this station exceeded the previous period-of-record maximum, recorded in 1996, by over fifty percent (figure 4). Although the flooding was significant in Burtonsville and to the mouth of the Schoharie Creek at the Mohawk River, the peak discharge per unit area was less than half of any other USGS streamgauge in the Schoharie Creek basin. This exemplifies the high degree of flooding generated in the higher elevations, where total discharge was less, but peak run off was over five times as great in some streams (table 1). When the Schoharie Creek entered the Mohawk River near Fort Hunter, NY, it contributed to serious flooding in communities downstream. The Mohawk River at Cohoes, NY (01358000) streamgauge experienced a 3.3-percent annual chance flood, much less extreme than anything experienced in the Schoharie Creek, primarily because of less intense rainfall in the upper Mohawk River, East Canada Creek and West Canada Creek basins.

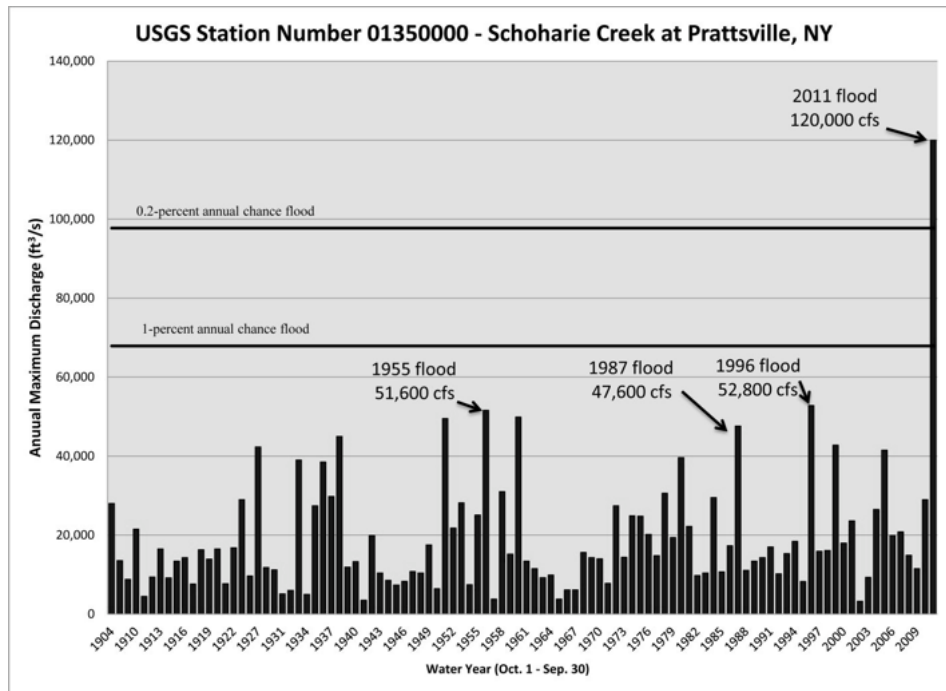

Figure 3: Annual peak discharges for the period-of-record at USGS station number 01350000 – Schoharie Creek at Prattsville, NY (0.2 and 1-percent annual chance of flood discharges from FEMA, 2008).

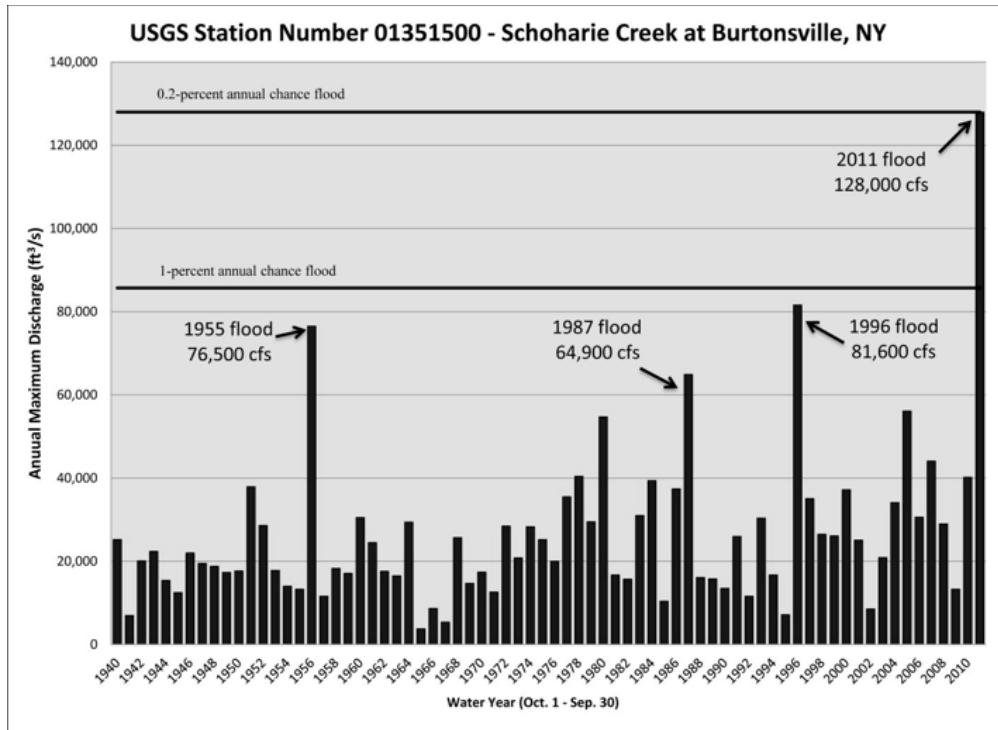

Figure 4: Annual peak discharges for the period-of-record at USGS station number 01351500 – Schoharie Creek at Burtonsville, NY (0.2 and 1-percent annual chance of flood discharges from FEMA, 2012).

Table 1: Peaks for the flood of August 28, 2011 at selected U.S. Geological Survey streamgages in the Schoharie Creek Basin.

| USGS Station number | USGS Station name | Drainage area (mi ²) | Peak Stage (ft) | Peak discharge (ft ³ /s) | Peak unit discharge (ft ³ /s/mi ²) |
|---------------------|--|----------------------------------|-----------------|-------------------------------------|---|
| 01349700 | East Kill near Jewett Center | 35.6 | 25.65 | 28,400 | 798 |
| 01349705 | Schoharie Creek near Lexington, NY | 96.8 | 22.87 | 34,100 | 352 |
| 01349810 | West Kill near West Kill, NY | 27.0 | 14.03 | 19,100 | 707 |
| 01349950 | Batavia Kill at Red Falls near Prattsville, NY | 68.6 | 21.40 | 44,200 | 644 |
| 01350000 | Schoharie Creek at Prattsville, NY | 237.0 | 24.38 | 120,000 | 506 |
| 01350101 | Schoharie Creek at Gilboa, NY | 316.0 | 40.72 | 111,000 | 351 |
| 01350180 | Schoharie Creek at North Blenheim, NY | 358.0 | 22.00 | 119,000 | 332 |
| 01351500 | Schoharie Creek at Burtonsville, NY | 886.0 | 17.52 | 128,000 | 144 |

Conclusion

The Schoharie Creek has experienced flooding for millennia. The USGS has been recording streamflow data in Schoharie Creek and its tributaries for just over a century to help monitor water resources, protect communities from flooding and to characterize the probabilities and extents of possible future flooding. The three events documented in this abstract demonstrate different contexts in which flooding has occurred in the Schoharie Valley and how the basins' response was documented by the USGS. The

information collected during the most recent floods of the Schoharie Creek help provide a better understanding of how events of this magnitude develop and in turn, how government agencies can aid in protecting life and property in the future.

All three floods (1987, 1996, 2011) significantly impacted the entire Schoharie Valley and will remain in peoples memories for years to come. It is important, from a hydrologic perspective, to understand the similarities and differences

between them. The 1987 flood was a spring flood from rainfall and run off atop soils saturated by previous snowmelt and rains. In 1996, a complex combination of heavy snowpack, warm moist air associated with the rain, and previously low flowing, ice packed streams contributed to the major floods that ensued. Lastly, in 2011, tropical storm Irene, followed closely by tropical storm Lee, delivered a flood over two times the magnitude experienced in some parts of the Schoharie Creek in over a century. This flood was the result of incredible amounts of rainfall, particularly in

the smaller basins within the headwaters of Schoharie Creek.

The damage caused by the August 28-29, 2011 floods was widespread and devastating. Events, such as the flooding after a tropical storm like Irene, seem to be unique based on historic records. Several floods in the past decades throughout the state demonstrate the unpredictability of individual events; however, with long-term monitoring, we can begin to understand the probability of an event of a given magnitude and investigate possible trends associated with climate change.

References

- Federal Emergency Management Agency, 1997, One Year later: Floods of January 1996: FEMA-1095-DR-NY, 8p.
- Federal Emergency Management Agency, 2008, Flood Insurance Study, Greene County, NY (All Jurisdictions): Flood Insurance Study no. 36039CV001A, 107p.
- Federal Emergency Management Agency, 2012, Flood Insurance Study, Schoharie County, NY (All Jurisdictions): Flood Insurance Study no. 36095CV000B, 100p.
- Lumia, Richard, 1998, Flood of January 19-20, 1996 in New York State: U.S. Geological Survey Water-Resources Investigations Report 97-4252, 61p. (<http://pubs.usgs.gov/wri/1997/4252/report.pdf>)
- National Weather Service, 2011: website - http://www.erh.noaa.gov/er/aly/Past/2011/Irene_Aug2011/PNS-StormTotal_Pcpn.txt. Accessed February 21, 2012
- Northeast Regional Climate Center, 2011, New York Climate, August 2011, vol. 111, no. 8, 15p. http://www.nrcc.cornell.edu/pubs/msmry_ny_2011-08.pdf. Accessed Feb. 21, 2012
- Zembrzuski, T.J., Evans, M.L., 1989, Flood of April 4-5, 1987, in Southeastern New York State, with Flood Profiles of Schoharie Creek: U.S. Geological Survey Water-Resources Investigations Report 89-4084, 43p. (<http://pubs.usgs.gov/wri/1989/4084/report.pdf>)

DEGRADATION AND AGGREGATION ALONG THE MOHAWK RIVER AND THE SCHOHARIE CREEK

Ashraf Ghaly, Ph.D., P.E.

Department of Engineering, Union College, Schenectady, NY 12308

Degradation and aggregation are natural phenomena observed in rivers and streams. Degradation occurs when banks are subjected to erosion due to weak soil conditions, high flow velocity, or a geometrical pattern that promotes the formation of flow vortices where soil structure can be easily compromised. Aggregation, on the other hand, is the phenomenon where soil and aggregate particles suspended in the water get transported and deposited as sediment layers along the waterway. The factors influencing aggregation are flow velocity, particle size of sediment transport, and the geometry of the water path. This paper will review experimental models conducted to study degradation and aggregation under various natural conditions. It will also use Geographic Information Systems (GIS) modeling, together with aerial imagery, to predict locations with greatest potential for degradation and aggregation to occur. These findings will be compared with actual locations along the Mohawk River and one of its major tributaries; the Schoharie Creek. Many of these locations were recently exposed to the severe weather systems (Tropical Storms Irene and Lee) that impacted a considerable portion of the Mohawk River watershed in late summer 2011. This study will show that both degradation and aggregation constantly alter stream dynamic and the flow in the waterway. This can constitute a challenge to the efforts of stream restoration, including buffering and protection systems.

Oral Presentation

AN INSIGHT INTO SHORELINE DAMAGE DUE TO STORMWATER SURGE

Ashraf Ghaly, Ph.D., P.E.

Department of Engineering, Union College, Schenectady, NY 12308

Field visits of sites along Priddle Road in the town of Esperance, NY in the wake of Tropical Storms Irene and Lee revealed a curious pattern of damage. Priddle Road runs parallel to the west (convex) side of about 90 degrees bent of the Schoharie Creek. Almost a half of a mile of shoreline properties were totally destroyed and washed away by the rushing water that rose significantly above historical flood levels. This segment of the Schoharie Creek is made of a tree-lined mild slope on the east (concave) side of the creek. A careful examination of the extensive damage that occurred in this area shows that the rushing water destabilized the slopes of the east side which resulted in the failure of enormous sections of soil and the felling of countless trees in the process. The collapsed soil and trees narrowed the waterway, which compounded the problem of the already excessive floodwater. This had the adverse effect of raising the water level much higher than normal and accelerating its already high velocity. With such effects in play, the west (convex) side of the creek gets compromised in the same fashion resulting in felling many trees that made the waterway even narrower, thus raising the water level much higher and adding greater destructive force to its rushing mass. Since the west side of the creek where the damaged properties stood is much lower in elevation than that of the east side, the energy with which the surging water hit the standing houses gave them no chance of withstanding a total destruction. It is worth noting that the vast majority of the damaged houses were not built of light weight material such as wood, rather they were made of concrete blocks and stones, and all were founded on a concrete foundation at some distance from the ground level. The soil in the area seems to be a mixture of silt and clay. Evidence of extreme scouring around and beneath supporting foundations was clear. Considering objects that had risen with surging water and were left behind suspended on standing tree branches, it can be said that floodwater level exceeded 10 feet above ground level. This paper will present a photo journal documenting the events that this segment of the Schoharie Creek was subjected to and the accompanying damage.

Poster Presentation

POST-IRENE SUSPENDED SEDIMENT DYNAMICS IN SCHOHARIE CREEK

David Gillikin¹, John Garver¹ and John McKeeby²

¹Geology Dept. Union College, Schenectady NY, ²Schoharie River Center, Burtonsville, NY

Hurricane Irene and Tropical Storm Lee caused major flooding and scouring of the Schoharie Creek watershed. These events resulted in a high total suspended matter (TSM) load that persisted for months after the floods. The high TSM is visible in Satellite imagery and the water color in these images above and below the confluence with the Mohawk River is drastic, with the Mohawk River being reddish/brown down stream of the Schoharie. To try to get a better understanding of the volume of sediment moving through the system and how that might change with time, we sampled Schoharie River water TSM daily at Burtonsville from 8 October 2011 to the end of December (2011). The background TSM concentrations during lower flow conditions steadily decreased from about 48 mg/L to 9 mg/L during mid-November. However, large pulses of TSM are still occurring, with TSM concentrations up to ~500 mg/L. These events are short lived (1 to 2 days) and some of them were undoubtedly related to high sediment mobility during channel restoration work. We also intermittently sampled the Mohawk River at Schenectady (Union College Boathouse), and we had three dates in October (19-21) where we could estimate the fraction of sediment in the Mohawk that can be directly attributed to Schoharie input. During these three days we estimate that the Schoharie contribution to suspended load in the Mohawk varied between 8 and 58%. These estimates are affected by active channel working (in the Mohawk) with heavy machinery during this time.

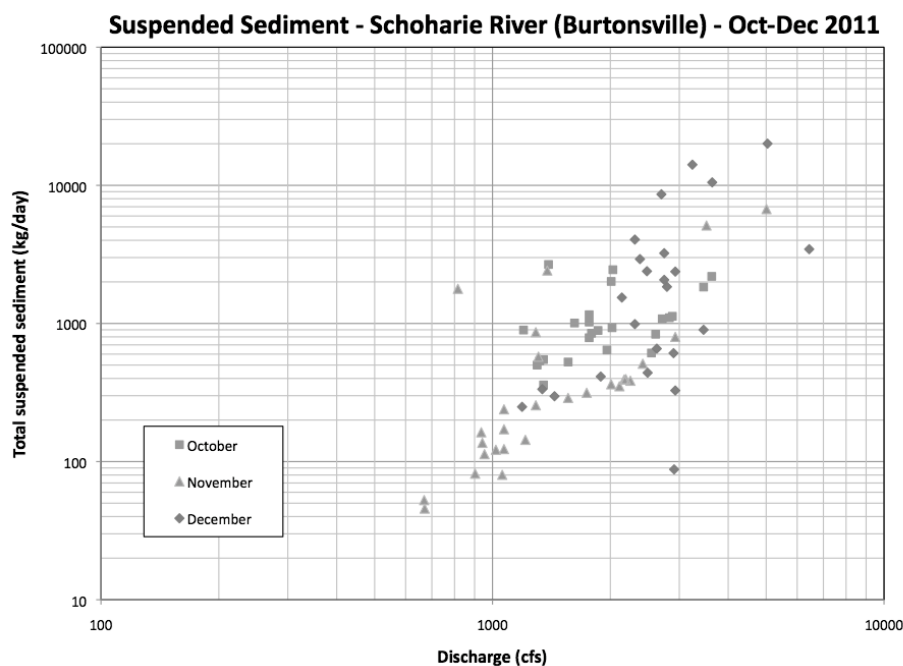

A POST HURRICANE IRENE RAPID BIOASSESSMENT OF THE WATER QUALITY OF THE SCHOHARIE CREEK AT BURTONSVILLE, NY

Mary Rachel Keville, Jacob Tanzman, Corrine Skala, Nick Marotta, Nick Lynch and John McKeeby
Schoharie River Center, Burtonsville, NY

Background

Schoharie River Center Environmental Study Team has been conducting rapid bio-assessments of the Schoharie Creek since 2002, collecting water chemistry, macro-invertebrate and bacterial data to assess water quality of the creek, and several of its tributaries between the Gilboa Dam and Burtonsville NY. On August 28 – 30, 2011 the creek was severely altered due to the devastating effects of Hurricane Irene and the subsequent record flooding of the entire Schoharie Watershed. To assess the damage and recovery of the Schoharie Creek following Hurricane Irene and Tropical Storm Lee between August 28 and September 5, 2011, high school student members of the EST have been conducting bi-monthly testing of the creek, measuring water quality at Burtonsville, with some surprising results.

The Schoharie Creek is a major tributary of the Mohawk River that is home to many towns and communities. Its headwaters begin at the base of Indian Head Mountain, located in the Catskills, Greene County, NY. It flows north through Delaware, Schenectady, Montgomery, and Schoharie counties and joins the Mohawk River at Fort Hunter. Land use, draining more than 2,300 square kilometers, is approximately 77 % forested, 20 % agricultural, 2 % urban, and 1 % other.

The Schoharie Creek was dammed in 1927 at Gilboa, NY, to create the Schoharie Reservoir, providing drinking water for New York City. The impoundment essentially severed the creek in half and changed its flow pattern and habitat, from below the dam to the confluence with the Mohawk River, the main stem of the creek was altered from a cold-water fishery (trout) to a warm water fishery (small mouth bass). No regular release of water occurs from the Schoharie reservoir, and during summer months the creek bed from the reservoir dam is essentially dry to Middleburgh, where minor tributaries begin to add enough water to recreate the creek.

August 28th, 2011 brought the major storm that incited record-breaking flooding of the creek, upwards of 15 feet of water, 2.5 times the National Weather Service Floodstage. Normally the Schoharie at Burtonsville averages a height from 1-4 feet of water during the summer months. (USGS 01351500 Schoharie Creek at Burtonsville) With the unprecedented flooding caused by Hurricane Irene the towns along the creek were forced to evacuate, and major damage was sustained throughout the watershed. Roads, bridges, and houses were washed away. The quality of the drinking water supply and the safety of the residents were compromised. Cleanup efforts began immediately, temporarily hindered by a second onslaught of flooding from Tropical Storm Lee in early September, raising the creek to a level of 9 feet. (USGS 01351500 Schoharie Creek at Burtonsville) The Schoharie River Center's Environmental Study Team initiated post flood water chemistry and macro-invertebrate assessment on 9/25/2012, about one month after the initial flooding event began. Water quality assessment by the EST began as soon as the water level had receded to a safe level, in order to better understand the impact the event may have on water quality of the Schoharie Creek.

The Schoharie creek at the testing site has been classified by the NYS DEC as class C waters, indicating that the creek is suitable for fish propagation and survival, as well as primary and secondary contact recreation. The Schoharie Creek is actively and heavily used for recreation, including but not limited to: swimming, kayaking, and fishing. Within the reaches of the study site, the area is primarily forested, but is host to agricultural and residential activities; potential pollutant sources from this area include septic systems, road runoff, agricultural practices, and other human impacts. This past year, the potential pollution sources have been greatly augmented due to the severe flooding resulting from Hurricane Irene, expanding the list of potential pollutants to include housing materials, fuel oil, soil and sediment and other such pollutants resulting from damage to home and property.

Results

Physical site assessment, chemical analysis, and collection and analysis of macroinvertebrate samples were performed eight times (Post Flood) at the test site from September 25, 2011 – February 16, 2012. These results were compared to pre flood testing results that were collected six times between July 19th, 2004 – July 22, 2011. Bacteriological testing (coliform) was conducted in March 2012 for comparison with pre-flood sampling.

Location: All samples were drawn at the same location on the Schoharie Creek, about ¼ mile below the Burtonsville Bridge. GPS location: N42°48.812 , W 074° 15.523.

The site is about 24 Kilometers from the confluence of the Mohawk River, downstream

from the village of Burtonsville, Montgomery County. The width of the stream bed at this location is about 50 meters wide, flow is generally characterized as fast moving and the substrate is rocky with a range of stone sizes from large cobble stones to boulders. The riparian zone prior to the flooding was generally good with natural vegetation and mature forest trees (hardwoods) growing to the waters edge. No invasive plant species such as Knotweed, or Didimo have been observed at the site prior to the flooding event. Because of the risk imposed by high water levels, post flood sampling first occurred on September 25, 2011, about 20 days after Hurricane Irene and 15 days after Tropical Storm Lee had produced record flooding the creek.

Water Chemistry Data for the Schoharie Creek at Burtonsville

| Date | 7/19/ 2004 | 10/2 2/ 2006 | 9/29 / 2007 | 6/29 / 2010 | 7/13 / 2010 | 7/22 / 2011 | 9/25 / 2011 | 10/9/ 2011 | 10/23 / 2011 | 11/2 / 2011 | 11/20 / 2011 | 12/21 / 2011 | 1/16 / 2012 | 2/16/ 2012 |
|-------------------------|---------------|--------------------|-------------------|-------------------|-------------------|-------------------|-------------------|---------------|--------------------|-------------------|--------------------|--------------------|-------------------|---------------|
| Temp °C | 24 | 9 | | 18 | 28 | 30.3 | 22.1 | 17 | 13 | 9.5 | 8.6 | 5 | 2.5 | 6.5 |
| pH | 8.8 | 8.4 | 9.2 | 8.6 | 9.1 | | 8.6 | 7.5 | 8.4 | 8.5 | 8 | 7.5 | 6.8 | 7.2 |
| Alkalinity (mg/L) | | 100 | 62 | | | 73 | 85 | 118 | 84 | 92 | 61 | 88 | 30 | 52 |
| Dissolved Oxygen (mg/L) | 7 | 8 | 8.2 | 8.4 | | 8.6 | 7.8 | 10 | 8.2 | 11.2 | 13 | 12.2 | 13 | 10.8 |
| Percent Saturation | 80.7 | 68.45 | | 71.2 | | 109.4 | 85.53 | 101.53 | 76.7 | 96.94 | 110.19 | 94.76 | 94.67 | 90 |
| Nitrate (mg/L) | 0.8 | 0.3 | 1.2 | 0.1 | 0.6 | 0.3 | 0 | 0.2 | 0 | 0.1 | 0.2 | 1.3 | 0.5 | 0.6 |
| Orthophosphate (mg/L) | 0.01 | 0.09 | 0 | 0 | 0.01 | 0 | 0.01 | 0 | 0.05 | 0.05 | 0.11 | 0.21 | 0.1 | 0.15 |
| Conductivity (µS/cm) | 284 | 273 | 147 | 325 | 304 | 225 | 215 | | | 220 | 205 | 220 | 180 | 178 |
| Turbidity (FAU) | 7 | 72 | 3 | 9 | 12 | 8 | 93 | 108 | 94 | 74 | 32 | 39 | 36 | 4 |

Schoharie Creek Water Chemistry Parameters. Darker diamond indicates point in time after flooding caused by Hurricane Irene.

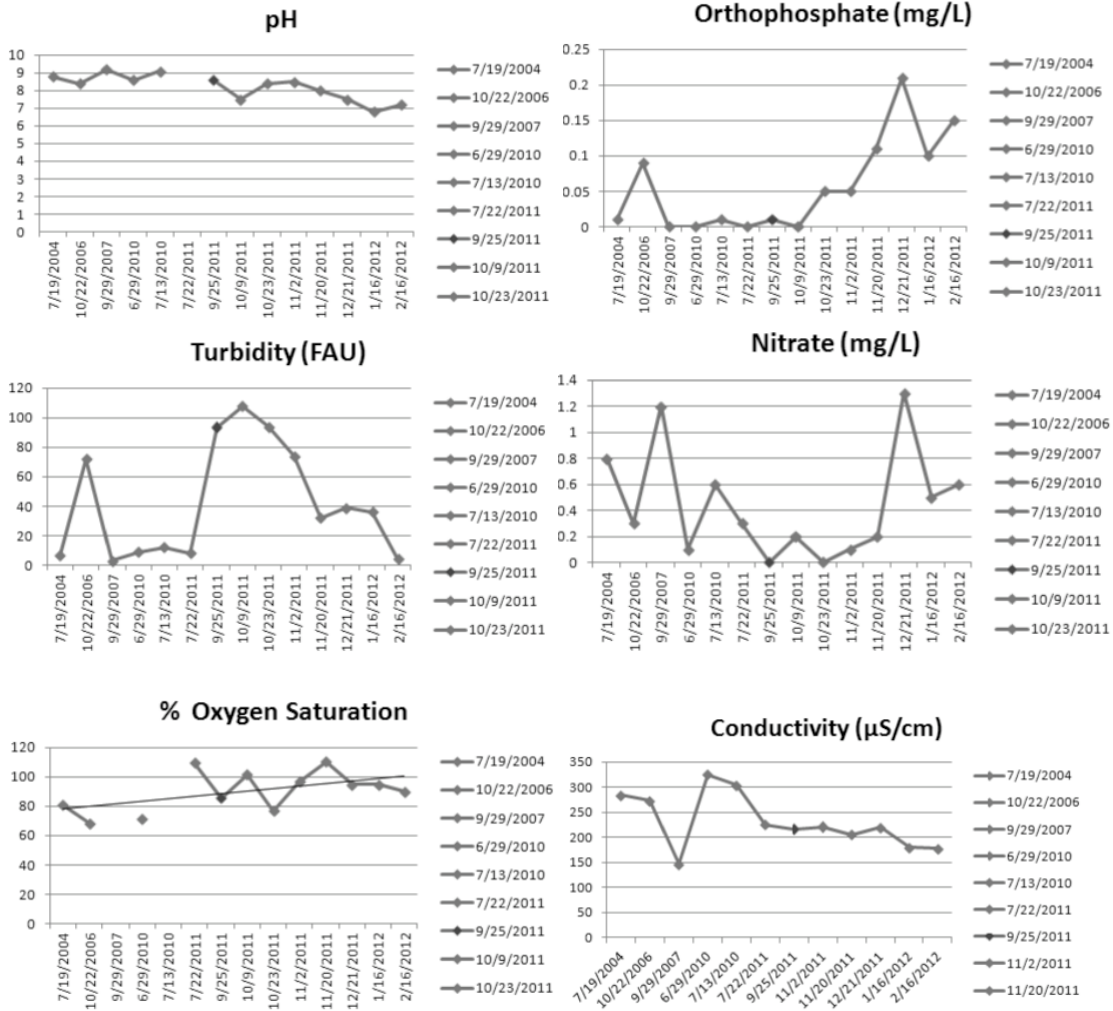

WIND EROSION CONTROL, OPTIMISATION BASED ON ARRAY AND DENSITY

Jason Krompart and Peter Nowell

Geography Department, University of Guelph, Guelph ON, Canada

Flooding frequently results in sediment deposition in non-fluvial settings such as agricultural lands and urban regions. While sedimentation on agricultural fields may increase soil nutrients and organic matter, sediment deposited in such a fashion is commonly susceptible to wind erosion due its loose structure and fine-grained texture. Resulting wind-blown particulate matter is not only detrimental to human and animal health but can cause undue economic stress due to property damage or losses in soil productivity. Utilising roughness elements within a wind-tunnel environment, this study sought to examine the impacts of roughness density and array on sediment deposition in order to effectively mitigate the negative corollaries associated with aeolian sediment transport. Three roughness densities were examined at wind speeds ranging from 9.0 m/s to 13.5 m/s utilising both a staggered and a random array. The results of this study seek to evince the benefits of optimising erosion control methods, such as vegetation or other roughness elements, in order to reduce airborne particulate matter. Optimisation of erosion control methods will not only benefit the health of individuals after major flood events, when wind erosion potential is at its highest, but will also reduce the amount of land put towards wind erosion control long after flood waters have subsided and erosion potential is trivial.

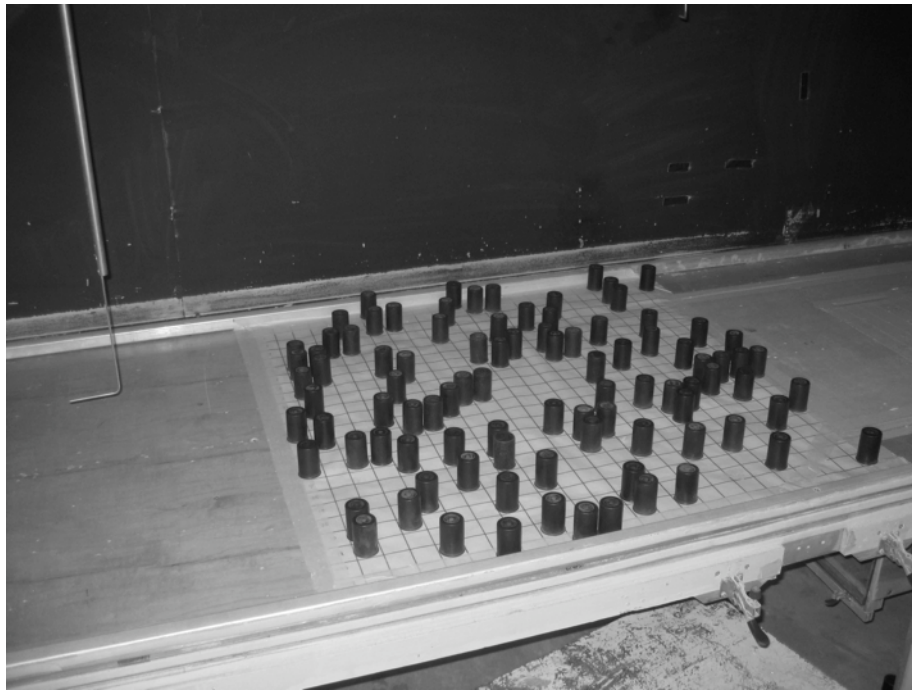

Figure 1: Experimental set-up of roughness elements utilizing a random array with 16.5% porosity.

References

- Hagen, L. J. (2001) Assessment of Wind Erosion Parameters Using Wind Tunnels. *Sustaining the Global Farm*, 742-746.
- Larney, F. J., Lindwall, C. W., and Bullock, M. S. (1994) Fallow management and overwinter effects on wind erodibility in southern alberta. *Soil Science Society of America Journal*, 58, 1788-1794.
- Snyder, W. H. (1972) Similarity criteria for the application of Fluid Models to the Study of Air Pollution Meteorology. *Boundary-Layer Meteorology*, 113-134

MOHAWK RIVER WATERSHED MANAGEMENT PLAN: ASSESSMENT PHASE OF WATERSHED CHARACTERISTICS

Win McIntyre

Consultant – Water Resources Management, Project Coordinator, Mohawk River Watershed Coalition

In the process of developing a watershed management plan, funded through a Title 11 Environmental Protection Fund Local Waterfront Revitalization Program grant from the NYS Department of State, watershed characterization was begun in order to set the stage for assessing current conditions, identifying needed actions and for formulating strategies to protect and restore water resources. The characterization consists of two phases, first the inventory of physical features, land uses, and pollution sources, followed by an assessment of water quality and living resources on a sub-watershed basis. The focus here is on the assessment phase.

The assessment will determine the relative "health" of a watershed's living and water resources. More specifically, the assessment of water resources will look at impairments, special protection or restoration needs, impact of land uses such as agricultural and forestry operations, impact of future development, and an estimation of runoff and pollutant loadings. For living resources, the assessment looks at inventory and habitat, habitat restoration and protection, and impairments.

How will this be done? What will be the basis for the assessment, and what process will be used? To answer these questions, a resource to use is the NYS Department of State's Guidebook - "Watershed Plans-Protecting and Restoring Water Quality". Additional resources include the studies of other watersheds, such as a recent study of the Black River watershed. From these, it's clear that a framework is needed that includes the assessment components (what will be looked at), and the indicators, or metrics that will be used to evaluate the condition of the components.

For the Mohawk River watershed, an assessment framework was developed based on issues and concerns raised by the Watershed Advisory Committee, with the main components being water quality, land use, and habitat. Within these components, specific indicators were selected for evaluation purposes. In total, there are fifteen indicators for the assessment components, and they include the following: Water Quality - % Impairment per WI/PWL, % Groundwater Recharge, % Wetlands & Forest, % Natural Riparian Cover; Land Use - % Agriculture, Soil Erodibility (K-Factor), Livestock/Acre of Pasture, % Forest, % Urban, % Impervious, and % Change in Building Permits since 1990; Habitat - % Aquatic Life Precluded, Impaired or Stressed, % Intolerant Fish Species, In-Stream Habitat Moderate to Severe Observations, Endangered Species Observations.

It was determined that the evaluation of sub-watersheds would be done at the 12-digit HUC level, of which there are 116 across the Mohawk River basin. In order to quantify the evaluation and determine a "score" for each sub-watershed, a 1-5 scale was developed for each of the indicators, with the low end of the scale indicating an unhealthy condition and the high end indicating healthy. For example, for % impairment under water quality, the scale is: 1 - >80%, 2 - 60.1-80%, 3 - 40.1-60%, 4 - 20.1-40%, and 5 - <20%. The indicator scores are added up to get the total score for each sub-watershed, with low scores showing the need for restoration and high scores the need for protection. And, with the power of GIS, all of this can be done automatically, with map layers created showing sub-watersheds scoring high, medium, and low for total score, or for the scores of each of the three components.

Given the information provided by the evaluation scoring of sub-watersheds, each of the Soil and Water Conservation Districts in the Mohawk River Watershed Coalition will conduct an assessment of the 12-digit HUC's in their county. The assessment will involve an analysis of the indicators behind the scores to better understand where the problems are for low scores, or what positive conditions result in high scores. With that understanding, recommendations will be made regarding the action steps needed to either restore an "unhealthy" sub-watershed or protect a "healthy" one. Photo documentation will also be included, as well as a summary narrative of each sub-watershed's assessment.

**AN URBAN WATERS PROGRAM PROPOSAL – BIOASSESSMENT, YOUTH TRAINING, AND
POST-FLOOD RIPARIAN RECOVERY OF THE SCHOHARIE AND LOWER MOHAWK
WATERSHED – A CALL FOR INVESTORS**

John McKeeby

Schoharie River Center, Burtonsville, NY

In 2012 the Schoharie River Center, in partnership with Union College and New York State DEC submitted a proposal to the United States Environmental Protection Agency's Urban Waters Grant Program. The grant program is highly competitive and only one grant proposal will be funded within each region. Each proposal must have a 25% local (non federal) match to be eligible for consideration.

This project is aimed at improving water quality, educating youth, and restoring the riparian buffer along the flood-damaged Schoharie and lower Mohawk Watershed in eastern NY State. Since 2001 the Schoharie River Center (SRC) has developed and operated a small network of Environmental Study Teams (EST) composed primarily of interested high school students from Urban (Schenectady), suburban (Duanesburg) and rural (Schoharie) communities throughout the Lower Mohawk Watershed. EST members participate in year-round, outdoor-based environmental studies, and research activities designed to introduce them to the scientific methods, practices, and skills necessary to assess the water quality of local streams, rivers, lakes, and ponds. The primary mechanism that we use to identify and remediate impaired water bodies in the watershed is through biological assessment of benthic communities, which we have successfully used to identify water quality impairments in the watershed – subsequent remediation was then taken over by the NYSDEC. In addition to biological assessments, we propose to plant and re-establish native vegetation on parts of severely damaged riparian zones, which were compromised during and after Hurricane Irene. This project establishes a unique working collaboration between the students and staff at the SRC, faculty at Union College, and scientists at the NYS Department of Environmental Conservation.

ESCAPING INUNDATION: THE CANOEING ADVENTURE OF A LIFETIME

Elizabeth Morgan¹ and Drew Pearson²,

¹Boy Scouts of America, Union College Geology '11, ²Wildwood School, Union College Math '08

The Mohawk River has been a major transportation route in New York since before the discovery of the New World. Throughout history people have used its waters for commerce, education, and exploration. During the historic days of August 24 – 27th of 2012, we had the once-in-a-lifetime opportunity to travel the entirety of the Mohawk River in a seventeen foot Grumman canoe. The path we followed was from the River's start, where Nine Mile Creek and the Oriskany Creek meet (Oriskany Flats) to its finish, The Niagara-Mohawk Power Dam at the Waterford Canal Lock 6 (Figure 1). At our start, we didn't know that our trip would also be the last time the NYS Canal System and the Mohawk River herself would ever be the same. The floods caused by Hurricane Irene and Tropical Storm Lee that ensued in the Mohawk watershed were not even in our purview as we started our trip and set our canoe adrift in the early morning, meandering down the small, calm stream in late August.

Our trip's purpose was to give reverence to one of the most important watersheds in the United States. Beginning the grueling expedition with almost no training, we set out from Oriskany, NY and covered approximately thirty miles on each of the first three days and seventeen miles on the final day of our exhausting voyage. The endurance required to accomplish that feat was fueled as much by our determination as it was by the majestic powers of the Mohegan waters. In this age of modern transportation and technology, of instant access and instant gratification, we found an extremely memorable and rewarding journey following a strikingly "unmodern" path.

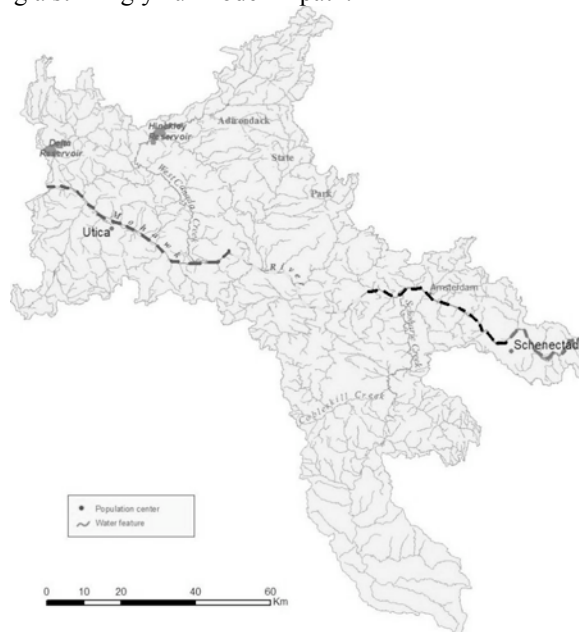

Figure 1: Detailed map of the Mohawk River watershed (NYS DEC, 2010). Major cities are noted with a dot, and approximate canoe route outlined with a dotted line (Red= day 1, Yellow=day 2, Black=day 3, Purple=day 4).

References:

New York State Department of Environmental Conservation, 2010, Bureau of Watershed Assessment and Management, Division of Water, The Mohawk River Basin Waterbody Inventory and Priority Waterbodies List (<http://www.dec.ny.gov/lands/53752.html>)

**MOHAWK RIVER WATERSHED MANAGEMENT PLAN: PROGRESS REPORT AND
INVENTORY OF PHYSICAL FEATURES, LANDUSE AND POLLUTION SOURCES USING GIS
COALITION OF CONSERVATION DISTRICTS**

David A. Mosher¹ and Katie Budreski²

¹Program Coordinator-Schenectady County Soil and Water Conservation District
¹Coalition Chairman – Mohawk River Watershed Coalition of Conservation Districts
²Project GIS Specialist – Stone Environmental Inc.

At the 2011 Mohawk River Watershed Symposium, a presentation was made on initial aspects of a project to develop a management plan for the Mohawk River watershed. A Coalition of fourteen Soil and Water Conservation Districts had been formed, which, through Montgomery County, was awarded a Title 11 Environmental Protection Fund Local Waterfront Revitalization Program grant from the NYS Department of State. The purpose of this report is to provide an overview of the project status, and then focus on the use of GIS to help describe watershed resources, and the power of GIS as a planning tool.

The process of developing a watershed management plan first includes a characterization of the watershed, which is a description and assessment of the waterbodies and watershed resources. The characterization provides the basis for developing strategies and action plans, which make up the management plan. Progress along this path over the past year included the completion of the following: (a) The preparation of a community outreach/participation plan and its presentation at regional meetings; (b) The creation of an initial vision of the watershed by the Watershed Advisory Committee; (c) An inventory of watershed resources using GIS; (d) a description and assessment of local laws, programs, and practices affecting water quality; and (e) an agreement to partner with the U.S Army Corps of Engineers for a watershed feasibility study. Most of the year's effort was on the development of a GIS database.

A comprehensive GIS database system was developed to characterize the Mohawk River Watershed. The database system includes 58 GIS datasets of physical features, land use, and pollution sources within the basin. There are fourteen Districts that will be utilizing and interpreting the datasets collected to develop the watershed management plan. This process will also include stakeholder involvement. While all districts have GIS, most have limited time to spend in a GIS system. To simplify the use of the GIS database and to provide access to multiple stakeholders, Stone developed a Web Map that holds all of the datasets collected for the project. The Mohawk River Watershed Web Map has tools to help navigate the datasets and share information amongst districts or with stakeholders. In addition to the Web Map, a suitability analysis tool was developed to analyze the impacts of varying types of management activities within the basin. A suitability analysis uses input GIS datasets and combines them using a weighted factor of importance to result in a final suitability layer. They can be used to determine areas suitable for groundwater protection, fish and wildlife restoration, growth center designation, or green infrastructure planning, among other examples. The tool is a desktop tool and is compatible with ArcGIS version 10.0.

POST FLOOD RECOVERY EFFORTS IN SCHOHARIE COUNTY FROM A CONSERVATION DISTRICT'S VANTAGE POINT

P.M. Nichols

Stream Program Manager, Schoharie County Soil and Water Conservation District

On August 25th 2011 the National Weather Service tracked Irene as a Category Three Hurricane moving Northwest at 12 mph. Predictions circulating around Schoharie County anticipated the storm making landfall at New York City and tracking East. The amounts of rainfall that fell on the Catskill Mountains and areas of Schoharie County were unexpected, and resulted in historic flooding in the Schoharie Valley. On August 28th 2011, flood evacuation sirens sounded throughout the Schoharie Valley before the main stem of the Schoharie Creek experienced 500-year flood flow elevations causing widespread damage. Feeder tributaries into the Schoharie Creek experienced severe bank erosion as well as backwater resulting in aggradation of sediment and woody debris jams at all the confluences. Bridges, cross culverts, and roadways were undermined causing several millions of dollars in damage. An estimated 1000 homes and business either experienced flood damage or were destroyed completely. Emergency operations were evacuated from their headquarters in Schoharie, and again from their temporary Emergency Operations Center (EOC) in Cobleskill when Tropical Storm Lee struck eleven days later. Lee spared the eastern parts of the county including the Schoharie Creek Watershed communities, but resulted in historic localized flooding in the western half of the county. Thus began a multiple agency recovery effort involving FEMA, SEMO, Army National Guard, Army Corps of Engineers, NYSDEC, NYSDOT, Schoharie County Public Works, Emergency Management, Sheriff's Dept., local highway dept.'s, and Schoharie County Soil and Water working collaboratively to begin an unprecedented recovery effort to protect public health and safety. Stream work during a thirty day Emergency Permit Authorization issued by NYSDEC allowed streams to be cleared of excess gravel and woody debris in an effort to protect key infrastructure, and multiple residences. Six months later, there still remains a need to evaluate stream conditions county wide to assess where needs still exist for providing long term solutions to stream stability. Using Natural Channel Design principles, assessment and subsequent restoration of streams by environmental agencies will likely continue for the next several years. Discussion of ways to mitigate future flood damage including aggressive floodplain management has begun at the county level. Local agencies are constantly seeking funding to support flood mitigation, education and outreach efforts, and acquisition for at risk properties. Some stream assessments have begun in an effort to gauge how these waterways will react to future high water events due to changes in their physical conditions (i.e. profile, slopes) as a result of the floods. Ecological assessments of several first and second order streams will begin in the spring of 2012 by SUNY Cobleskill Fish and Wildlife Department and Chemistry students and staff. Using historical data collected at specific reaches; teams will assess any significant changes that may have occurred in these locations regarding physical/chemical water quality, macro-invertebrate EPT indexes, fish populations, and stream gradient. This data will assist environmental agencies in determining flood effects on the overall bio-diversity of these waters throughout the county. Concise survey data such as this will help local agencies ascertain whether or not future mitigation work on these streams will be necessary. Discussions have also begun for developing strategies to restore stream banks that have been denuded of important soil stabilizing riparian vegetation. Areas to focus on would be key flood prone locations along the Schoharie Creek main stem, and several feeder tributaries. Volunteer planting projects designed to address this have already started to materialize, and restoration efforts will be ongoing for several years.



A southeast view of Schoharie Ck at Pindar Flats in Middleburgh

NYSDEC MOHAWK RIVER BASIN PROGRAM: BUILDING COLLABORATION AND PARTNERSHIPS IN THE BASIN

Alexander J. Smith and Katherine Czajkowski

New York State Department of Environmental Conservation, Division of Water

Introduction

In April of 2009, the New York Ocean and Great Lakes Ecosystem Conservation Council issued a report to the Governor and the Legislature titled “Our Waters, Our Communities, Our Future”. The report outlined a set of recommendations to help New York State better manage natural resources and human activities in its ocean and Great Lakes regions by implementing an Ecosystem-based Management (EBM) approach. EBM is an innovative approach to management that recognizes that humans are integral parts of ecosystems and that healthy ecosystems are vital to support vibrant human communities.

As part of developing the 2009 Report, the New York State Department of Environmental Conservation’s (NYSDEC) Hudson River Estuary Program was evaluated for its consistency with EBM principles. Through that review, it was recommended that the Estuary Program should evolve toward a “whole Hudson” approach, in order to more fully consider all the factors contributing to the health of the Hudson River ecosystem, including its human component. Consequently, the report proposed that the Hudson River Estuary Program should be replicated in the Mohawk River and Upper Hudson watersheds with crosscutting issues identified and cooperatively managed.

Acting upon this recommendation, the NYSDEC initiated the Mohawk River Basin Program (MRBP) and along with various other partners and stakeholders developed the Mohawk River Basin Action Agenda. The mission of the Mohawk River Basin Program is to act as coordinator of basin-wide activities related to conserving, preserving, and restoring the environmental quality of the Mohawk River and its watershed, while helping to manage the resource for a sustainable future. Vital to the success of the program are the involvement of stakeholders and the creation of partnerships with established programs and organizations throughout the basin.

The development of the Action Agenda promoted integrated and coordinated

management of the environmental and cultural resources of the river and its watershed. While modeled after action agendas of the Hudson River Estuary Program and other successful watershed and estuary programs, it reflects the concerns and needs unique to the Mohawk Valley region. The Action Agenda was developed in collaboration with various local, state, and federal agencies and organizations, including the Departments of State, Agriculture and Markets, and Parks, Recreation and Historic Preservation, National Parks Service, New York State Canal Corporation, U S Geological Survey, County Soil and Water Conservation Districts, and regional planning organizations. Through collaboration with partners, the Action Agenda seeks to leverage external resources to achieve shared priorities.

Action Agenda Goals

The Action Agenda focuses on a list of measurable goals the MRBP will strive to achieve. The list of goals is a template by which the MRBP directs its actions. Each goal has specific actions associated with them and a time frame by which to complete them. These actions should be considered steps, which lead to the fulfillment of this list of Action Agenda Goals. Five priority goals are defined for the Mohawk River Basin, which if fully realized, would enhance ecosystem health and the vitality of the region for people and their communities.

The goals of the MRBP Action Agenda are as follows:

1. **Understand and manage fish, wildlife and their habitats** in the Mohawk River watershed while communicating to the public about their value to human communities and natural processes so that people can fish, hunt, trap, bird-watch, and enjoy the unique character of the valley and its living ecosystem.
2. **Protect and improve water quality in the Mohawk River watershed** so that people are protected from health hazards, drinking water supplies are conserved, aquatic animal communities flourish and natural processes are sustained.

3. **Reduce the consequences of flooding events** on Mohawk River Valley communities so that communities are prepared for climate change and cultural, recreational, economic and environmental heritage is protected.

4. **Revitalize Mohawk Valley communities** using sustainable development principles creating vibrant, healthy, desirable places to live, work and visit, capitalizing on the region's historic, cultural, environmental and recreational resources.

5. **Maintain working landscapes**, by supporting well managed farms and forest lands that sustain the agricultural economy, rural land use and open space in the Mohawk Valley while protecting the natural environment.

Implementation of the Action Agenda is guided by a Steering Committee of key partnering agencies and organizations. In addition, DEC staff coordinators started in the fall of 2011 to facilitate the implementation process and to assist with coordination among partnering organizations.

Creating a Mohawk River Valley Identity

Through coordination of basin activities, promoting the collaboration of program partners, and developing an Action Agenda on a five-year cycle the MRBP will help to develop a unified Mohawk River Valley Identity. The Mohawk River Valley is unique in its cultural and environmental resources and deserves the attention of State and Federal resources to enhance both the human and ecological economies of the region. The only way this will be realized is through a unified effort of collaboration among all stakeholders working in the basin. An enormous undertaking, this can be accomplished by supporting programs like the MRBP and working within the framework and goals of the Action Agenda.

The MRBP has already begun to form the relationships and implement projects that embody this spirit of collaboration. Over time these efforts will only be expanded upon. Some examples of the current work being done include:

1. **Mohawk River Basin Program Trees for Tribes** – Providing no- or low cost trees and shrubs to restore riparian corridors affected by Hurricane Irene. Collaborators include NYSDEC, Soil and Water Conservation Districts (SWCD) and Natural Resources Conservation Service (NRCS).

2. **Inventory of Sub-basin Waterway Habitat Connectivity** – An assessment of select subwatersheds in the basin to identify priority areas for improving aquatic habitat connectivity. Collaboration is with SUNY Albany.

3. **River Herring Survey of the Lower Mohawk River** – The beginning of implementing the NYSDEC Lower Mohawk River Management Plan recommendations to carry out River Herring surveys on the river to document population and resource dynamics. Collaboration is between NYSDEC Regional Fisheries, SUNY College of Environmental Science and Forestry, and the NYSDEC Hudson River Fisheries Unit.

4. **Mighty Waters Flood Workshops** – At the request of Congressman Tonko's Mighty Waters Committee, participating in educational workshops on reducing the consequences of flooding in the basin.

5. **Environmental Study Team Program** – Assisting the Schoharie River Center expand its Environmental Study Team Program into other areas of the Mohawk Basin through participating in funding applications to EPA. Collaboration is between The Schoharie River Center, Union College and the NYSDEC.

IN IRENE'S AND LEE'S WAKE: PUTTING THE PIECES AND PLACES OF THE ERIE CANAL BACK TOGETHER

Brian Stratton

Director, New York State Canal Corporation

Hurricane Irene resulted in substantial rain throughout the eastern Mohawk Valley between August 28 and August 30, 2011. The heaviest rainfall occurred in the headwaters of the Schoharie Creek watershed, where over 12 inches of rain were measured in a twelve-hour timeframe in Tannersville, NY. Schoharie Creek flows exceeded the largest rates ever recorded prior to this event by approximately 50 percent. These record flows resulted in widespread flooding along the Erie Canal/Mohawk River downstream of the confluence of the Schoharie Creek and the Erie Canal in Fort Hunter. In fact, record flood levels since the Erie Canal was constructed in 1915 were observed at Lock E-7 (Vischer Ferry), Lock E-9 (Rotterdam Junction), Lock E-10 (Cranesville), Lock E-11 (Amsterdam), and Lock E-12 (Tribes Hill). Observed flood levels at each of these navigation locks, associated with the record flow rates and the accumulation of substantial debris at the movable dams adjacent to the navigation locks exceeded record levels by many feet. The forces associated with the record flooding and accumulated debris resulted in significant structural damage to both the movable dams and the associated canal facilities. Guy Park Manor, a Georgian house built in 1773 at Lock E-11 (Amsterdam) was severely damaged by the floodwaters (Figure 1).



Figure 1. Hurricane Irene floodwaters impact Lock E-11 and Guy Park Manor in Amsterdam.

Just as Canal Corporation staff were conducting damage assessments and developing plans for the reopening of the Erie Canal, the remnants of Hurricane Lee wrung out another round of heavy rain throughout the Mohawk Valley, between September 7 and September 9, 2011. Substantial flooding resulted at the same locations that were just flooded by Hurricane Irene. The saturated lands adjacent to Lock E-8 (Scotia), Lock E-9 (Rotterdam Junction), and Lock E-10 (Cranesville) were washed away. At these locations, water flowed around the debris-choked movable dams and carved new deep channels around each lock resulting in widespread damage. This washed away historic powerhouses and the eroded sediment was deposited in the canal channel. Significant damage occurred at Lock E-9 (Rotterdam Junction) where the northern portion of New York State Route 103 was completely washed away (Figure 2).



Figure 2. New York State Route 103, adjacent to Lock E-9 in Rotterdam Junction, was washed away following Hurricane Lee.

In the aftermath of Hurricane Lee, expanded damage assessments and a much larger task to repair the extensively damaged Erie Canal infrastructure was undertaken. A plan to complete sufficient repairs necessary to reopen the Erie Canal on a target date of November 26, 2011 was adopted.

The re-opening of the Erie Canal on November 20, 2011 (Figure 3), following the catastrophic damage associated with Hurricanes Irene and Lee was a testimony to the spirit and determination of the entire Canal Corporation's staff. Structural steel repairs to the movable dams, dredging of the navigation channel, debris removal, and a myriad of other repairs were made in order to facilitate this re-opening. Considerable work remains to complete the repairs and return the damaged areas to their pre-storm condition. The Canal Corporation remains committed to completing these repairs and to the on schedule opening of the Erie Canal on May 1, 2012, marking the 188th consecutive navigation season, weather and water level permitting.



Figure 3. The cruise ship Grande Mariner navigates through the re-opened Erie Canal at Lock E-9, Rotterdam Junction as repair efforts continue.

MAJOR FLOODS OF 2011 IN NEW YORK

Thomas Suro

United States Geological Survey, New York Water Science Center

Three individual storm events produced heavy rains across the central and eastern parts of New York resulting in major flooding during 2011. The first storm event produced a total of 3 to 5 inches (in.) of warm rain that combined with significant snowmelt to produce widespread flooding in northeastern New York during April 27 – May 2, 2011. The National Weather Service (NWS) reported a 3 day rainfall total of 3.8 in. at North Lake Placid and a 4 day rainfall total of 4.6 in. at Indian Lake. Major flooding was reported by the NWS in the following basins: Ausable River, Lake Champlain, Hudson River, Raquette River, Sacandaga River, Schroon River, and West Canada Creek. The second storm event occurred in late August when Hurricane Irene weakened to a tropical storm as its center of circulation moved over New York City on August 28, 2011. Heavy rains associated with this tropical storm caused major flooding and damage throughout many parts of eastern New York on August 28-29, 2011. The National Weather Service (NWS) reported preliminary rainfall totals for parts of eastern New York that ranged from about 4.2 in. in Albany to over 6 in. at many locations in Columbia, Delaware, Dutchess, Greene, Schenectady, Schoharie, Ulster and Washington counties. Over 11 in. of rain was reported at Slide Mountain, greater than 13 in. was estimated for East Jewett, and greater than 18 in. of rain was reported at Maplecrest. The third storm event followed on the heels of the August flooding as remnants from Tropical Storm Lee produced rainfall amounts of 5 to 6 in. in many areas across parts of central and eastern New York, with localized amounts in excess of 8 in. causing record flooding in the Susquehanna River basin and moderate flooding in other parts of the State.

During the flooding of April 27- May 2, 2011, ten US Geological Survey (USGS) streamgages in the Hudson and St. Lawrence River basins recorded new record maximums. As an example, the Hudson River at North Creek (01315500) streamgage, in operation since 1907, recorded a new period-of-record maximum discharge of 36,100 ft³/s on April 28, 2011, which exceeded the previous record of 28,900 ft³/s recorded in December of 1948. During the sequential flooding of August 28-29, and September 7-8, 2011, more than 55 USGS streamgages recorded new period-of-record maximums as a result of these storms. In the St Lawrence River basin the Ausable River (04275500) and the East Branch Ausable River (04275000) near Au Sable Forks streamgages have both been in operation for more than 90 years and each recorded a new period-of-record maximum during the August event. In the Schoharie Creek watershed most streamgages recorded new period-of-record maximums that exceeded the previous records set back in 1996. The Schoharie Creek at Prattsville (0135000) streamgage, in operation since 1902, sustained major damage during the flood and a peak water-surface elevation and discharge of 24.38 ft and about 120,000 ft³/s, respectively, were determined as the new provisional period-of-record maximums set on August 28, 2011. The new period-of-record peak water-surface elevation is about 5 feet (ft) higher than the previous maximum and the peak discharge more than twice the previous record discharge set in 1996. Along the Batavia Kill, a tributary to the Schoharie Creek, the Batavia Kill at Red Falls near Prattsville streamgage also recorded a new period-of-record maximum discharge that was more than twice the previous peak discharge that occurred in January 1996. During September 7-8, 2011, streamgages along the Susquehanna River at Vestal (01513500) and Owego (01513831), just downstream from the City of Binghamton, recorded new peak water-surface elevations that exceeded the June 2006 levels by about 2 ft. The peak discharges and water-surface elevations recorded at these streamgages in 2006 exceeded the long-standing records set back in 1936.

Preliminary estimates of the recurrence intervals (or exceedance probabilities) for peak discharges recorded during these floods indicate that about 20 USGS streamgages recorded peak discharges that exceeded the estimated 100-year recurrence interval (less than 1-percent probability of occurrence in any given year).

MIGHTY WATERS

Congressman Paul Tonko

21st Congressional District New York

The mission of Congressman Tonko's Mighty Waters Task Force is to help create a climate of investment, recovery and public awareness for the waterways and communities of the upper Hudson and Mohawk Rivers and Erie Canal by mobilizing federal resources that encourage policy reform, economic development, public enjoyment and effective environmental stewardship. Following the devastating floods of August and September of 2011, Congressman Tonko has worked to promote a dialogue among local non-profits, the higher education community, federal, state and local government and other stakeholders to encourage coordinated efforts for flood mitigation and management and long-term environmental and economic recovery in the Mohawk River Basin. Congressman Tonko recently announced that Union College would host his Third Annual Mighty Waters Conference on June 13, 2012.

METEOROLOGICAL FACTORS THAT RESULTED IN EXTREME RAINFALL DURING TROPICAL STORM IRENE

**Joseph Villani, Stephen DiRienzo, Hugh Johnson, Vasil Koleci, Kevin Lipton, George Maglaras,
Kimberly McMahon, Timothy Scrom, Thomas Wasula, and Britt Westergard**
NOAA/NWS Weather Forecast Office, Albany, New York

During the early morning of 28 August 2011, Tropical Storm Irene produced extremely heavy rainfall across eastern New York and western New England, which resulted in record flooding along several rivers. The heavy rainfall and record flooding were especially prevalent across the eastern Catskill River basins, including the Schoharie Creek, which fed downstream into the Mohawk River. A maximum area of 30 cm to 45 cm (approximately 12-18 in.) of rainfall fell across the elevated terrain of Greene County, which was followed by extreme runoff into the Schoharie basin. This area received much more rain than the rest of the Albany Forecast Area from the land-falling tropical storm. This presentation will primarily investigate the meteorological factors that contributed to the extreme rainfall in the eastern Catskills.

There were several key factors that enhanced rainfall amounts in the eastern Catskills, primarily in Greene County. One factor in particular likely contributed significantly to the extreme rainfall maximum. Low-level north-northeast winds with speeds of 25 m/sec (anomalies of +5 to +6 standard deviations above normal) were oriented perpendicular to the northeast portion of the Catskills in central Greene County. It is hypothesized that upslope enhancement was particularly significant in this area due to the strong low level winds having a direction perpendicular to the escarpment. Also, the steepness of the escarpment has a dramatic elevation rise of over 900 meters in a short distance. The areas which received over 30 cm of rain were directly downstream of where this upslope enhancement likely occurred.

It is also hypothesized that steeply-sloped frontogenesis was a significant factor contributing to the extreme rainfall. The magnitude and depth of the frontogenesis noted during Irene is not typical of most tropical cyclones, implying that extra-tropical transition was occurring as Irene approached southern New England. A cross-section of the frontogenesis fields during the event will be shown, which implies the presence of strong upward vertical motion. The vigorous ascent in the lifting air parcels in a moist tropical environment was an important contributor to the copious rainfall amounts.

Antecedent conditions also played a significant role in the magnitude of flooding across the area. Rainfall for August was above normal prior to Irene, so ground water tables were already running high. This was in contrast to Tropical Storm Floyd, which impacted the area with heavy rainfall 16-17 September 1999. Dry conditions were in place prior to Floyd, with some areas approaching drought status. Flooding was not nearly as severe during Floyd as it was for Irene. Also, rainfall during Floyd had a longer duration, lasting 18 to 19 hours, while Irene's duration was only 12 to 13 hours. Thus, the rainfall rates were around 40% higher during Irene, which also contributed to severe flash flooding.

SCHENECTADY COUNTY WATER RESOURCES ORGANIZATIONS

Mary Werner

Board Member, Schenectady County Environmental Advisory Council

The Schenectady County Environmental Advisory Council (SCEAC) has recently established a committee to work on issues related to water resources in the County. As a first step, the committee is compiling information on all programs and organizations that are currently involved in water-related studies, evaluation and management activities. The purpose of the poster session is to inform symposium attendees as well as to ensure validity of the compiled information and to assist SCEAC in the development of a publication for broader distribution and use.

THE HYDROLOGY OF TROPICAL STORMS IRENE AND LEE

**Britt Westergard, Joseph Villani, Stephen DiRienzo, Hugh Johnson, Vasil Koleci, Kevin Lipton,
George Maglaras, Kimberly McMahon, Timothy Scrom, and Thomas Wasula**
NOAA/NWS Weather Forecast Office, Albany, New York

Tropical Storm Irene produced extremely heavy rainfall across eastern New York and western New England from August 27th through August 28th. A maximum area of storm total precipitation of 12 to 18 inches (30 to 46 cm) fell across the elevated terrain of Greene County. A New York State 24-hour rainfall record was set at a National Weather Service (NWS) rain gage at Tannersville, NY. Record flooding occurred at thirteen forecast points in the NWS-Albany Hydrologic Service Area. Heavy rainfall and record flooding were especially prevalent across the eastern Catskill river basins, including the Schoharie Creek, which fed downstream into the Mohawk River.

Nine days after Tropical Storm Irene, the remnants of Tropical Storm Lee produced storm total rainfall amounts of 3 to 6 inches (7 to 15 cm) with isolated areas of 7 to 8 inches (17 to 21 cm) across eastern New York and western New England. While the Mohawk watershed did not receive the 8 to 12 inches (20 to 30 cm) of rainfall that caused major to record flooding throughout the Susquehanna watershed, the rainfall it did experience, combined with antecedent saturated soils following Tropical Storm Irene, produced major flooding in the western Mohawk watershed and minor to moderate flooding elsewhere.

In addition to reviewing the hydrologic effects of these two events, this presentation examines the operational challenges of forecasting widespread rapid rises to record flooding. In addition, some of the actions taken by the National Weather Service since these events are discussed; including updates to flood stage and impact statements for river forecast points.

NEW YORK'S SHALE PLAYS AND WATER RESOURCES

John Williams

United States Geological Survey

Recent advances in extraction technology have made shale plays the hottest energy-development targets in the United States. New York has two of these unconventional shale plays – the Marcellus and the Utica. The geology of the Marcellus and Utica shales and technology used to develop hydrocarbons from them will be discussed. Potential water-resource impacts associated with development of the shale plays and best practices to mitigate those impacts also will be presented.

The Marcellus and Utica shales are the most extensive of a series of black, organic-rich shale formations deposited in the Appalachian Basin during the Devonian and Silurian Periods. The Marcellus and Utica plays currently are being developed in Pennsylvania, West Virginia, and Ohio through state-of-the-art technology involving horizontal drilling and hydraulic fracturing. Six horizontal legs 4,000 to 5,000 feet long are drilled per multi-well pad and 3 to 5 million gallons of water are used for fracturing each leg.

Water-resource issues associated with development of the shale plays include the 1) impact of surface-water withdrawals for fracturing during low-flow periods, 2) disposal of black-shale drill cuttings that may produce acidic, metals-rich drainage, and 3) treatment of frac flowback that contains elevated dissolved solids and radioisotopes. Surface spills of fracturing fluids and flowback and problems with casing and grout seals that allow migration of saltwater and gas to freshwater aquifers pose the greatest threats to the water resources.

Best practices to mitigate impacts on the water resources include 1) characterization of freshwater aquifers and shallow gas and saltwater by geophysical and mud logging, 2) installation and grouting of surface and intermediate casings to isolate freshwater aquifers from shallow gas and saltwater, 3) evaluation of grout seals by cement-bond logging, 4) offsite disposal of black-shale drill cuttings, 5) cumulative and low-flow assessment of frac water withdrawals, 6) onsite frac fluid and flowback storage in tanks, 7) avoidance of fracturing near high-angle structures delineated by seismic surveys, 8) microseismic monitoring during fracturing, 9) reuse of frac flowback water, and 10) groundwater-quality monitoring before and following drilling and fracturing operations.