

Lab 5: Ballistic Pendulum

Name: _____

Lab Partner(s): _____

Honor Code Statement: I affirm that I have carried out my academic endeavors with full academic honesty. _____

Please neatly answer all of the questions in the lab packet. Make sure you attach any graphs generated, Excel files you produced, and any calculations/derivations you did. This lab packet is due one week from the completion of the lab.

Introduction

The Ballistic Pendulum

Before the invention of radar, armies would measure the speed that a cannon ball is shot from the cannon, or the “muzzle speed” of a rifle by firing them into a pendulum and measuring how high the pendulum swung. The calculation requires analysis of the collision between the ball and pendulum, followed by the conservation of energy in the swing of the pendulum. We will return to the ideas of lab experiment #2 to determine the launch speed of a ball by using the equations of projectile motion using the launcher shown in Figure #1. Then we will turn our attention to determining the muzzle velocity by applying the ideas of conservation of momentum and conservation of energy as shown in Figure #2.

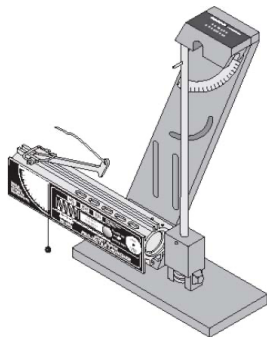

Figure 1: The ballistic pendulum apparatus.
<https://www.pasco.com/products/lab-apparatus/mechanics/projectiles/ballistic-pendulum>

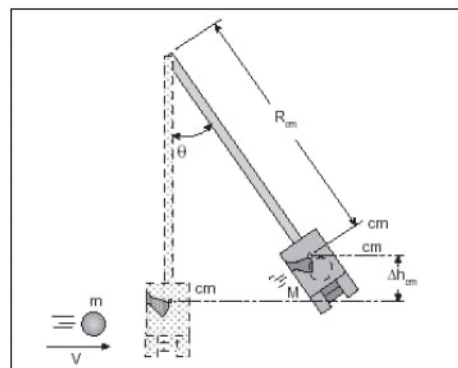

Figure 2: Figure 2: A ball of mass, m , and speed, v , is caught by the pendulum, which swings up to an angle θ .
<https://www.pasco.com/products/lab-apparatus/mechanics/projectiles/ballistic-pendulum>

The Experiment

Part 1: Using kinematics to determine the muzzle velocity of a ball.

- a. Clamp the projectile launcher to the edge of your lab table and set it up to launch the projectile horizontally. Make sure that the launcher is pointing in a direction such that the projectile can travel a horizontal distance of about $2m$ without hitting anything. Measure the height h of the muzzle from the floor and record it below along with an estimated uncertainty as $y \pm \Delta y$ with the proper number of significant digits.

$$h = y \pm \Delta y =$$

- b. Load the ball on the medium range setting and fire it. Measure the horizontal distance D the ball lands from the launcher and record it as $x \pm \Delta x$ with the proper number of significant digits.

$$D = x \pm \Delta x =$$

- c. Derive an expression for the launch speed of the ball, $v_{expression}$ and then evaluate the expression v_{PM} using the numbers you have. There is space on the next page to work out the derivation of the expression for the velocity and its uncertainty.

$$v_{expression} =$$

$$v_{PM} =$$

Space for the derivation of the velocity using projectile motion.

Part 2: Using the ballistic pendulum to determine the muzzle velocity of a ball.

- a. Remove the pendulum and obtain and record the masses of the ball and pendulum and their uncertainties.

$$m_b \pm \Delta m_b =$$

$$m_p \pm \Delta m_p =$$

- b. Determine the center of mass of the pendulum *with the ball in it* by finding the point where it best balances on the edge of a ruler. Measure the distance from the pivot point to this balance point and its uncertainty.

$$R_{cm} \pm \Delta R_{cm} =$$

- c. Reattach the pendulum, insert the ball into the launcher, and set it to medium range.
- d. Let the pendulum hang at its vertical position and move the angle indicator to zero degrees. Fire the launcher and note and record the angle reached.
- e. Reload the launcher and set the angle indicator to an angle of 5° less than that reached in step 4. This will nearly eliminate the drag on the pendulum caused by the angle indicator.
- f. Fire the launcher and record the angle reached by the pendulum.
- g. Repeating steps 5 and 6, complete 10 trials.
- h. Applying conservation of momentum and energy, derive an expression for the launch speed of the ball $v_{expression}$ and then evaluate the expression v_{BP} with the numbers you have. There is space available on the next page to work out the derivation of the expression for the velocity and its uncertainty using the ballistic pendulum.

$$v_{expression} =$$

$$v_{BP} =$$

Space for the derivation of the velocity using the ballistic pendulum.

Part 3: Using a photogate to determine the muzzle velocity of a ball.

- a. Remove the pendulum from the apparatus and place the photogate so that the full diameter of the ball passes through the gate immediately after leaving the launcher.
- b. Use the calipers to measure the diameter of the ball.
- c. Open Capstone (then click on “remind me later” in the first window)

Click “hardware setup” in the upper left.

Click on port 1 in the image.

Under hardware setup choose *photogate, one flag*.

Click on the blue cog in the lower right corner of the hardware setup dialog box and set the flag width to the width of the ball.

Click “ok” in the dialog box.

Click “hardware setup” again to make hard hardware setup box go away.

Select “classic templates” and choose the first option (includes a table).

In the table, click on “select measurements” and choose speed (*m/s*) and time in gate (in *ms*) for the two columns.

Load the ball in the medium range setting.

Click “Record” (in lower left corner) and fire the ball through the photogate, then click “Stop”

Note and record the measured speed of the ball.

- d. Obtain 10 measurements of the launch speed using the photogate. Average the results and determine an uncertainty in the launch speed from two times the standard deviation of the mean given from

$$\Delta v = 2\sigma_m = 2\left(\frac{\sigma}{\sqrt{N}}\right).$$

$$v_{\text{photogate}} \pm \Delta v_{\text{photogate}} =$$

Analysis

- a. What was your expression for and value of the launch speed of the ball using projectile motion?

$$v_{expression} =$$

$$v_{PM} =$$

- b. What was your expression for and value of the launch speed of the ball using the ballistic pendulum?

$$v_{expression} =$$

$$v_{BP} =$$

- c. What was your expression for and value of the launch speed of the ball using the photogate?

$$v_{photogate} \pm \Delta v_{photogate} =$$

- d. Looking back at lab #1, what was your value of the launch speed of the ball using projectile motion from lab experiment #1?

$$v_{expt 1} =$$

e. How do the above results compare? Do they all agree or not? Explain.

f. Which method (projectile motion, ballistic pendulum, or photogate) do you think is the best way to determine the launch speed of the ball? Explain.

g. Derive an expression for and then evaluate it for the fraction of the initial kinetic energy of the ball was lost to the collision with the pendulum. There is space on the next page to work out the derivation of the expression.

$f_{lost,expression} =$

$f_{lost} =$

This page is for the derivation of the expression for the fraction of the energy lost to the collision of the ball with the pendulum arm.