

## ***Experiment #2: Resistor Capacitor Circuits***

**Introduction:** We have seen how a capacitor charges and how that same capacitor discharges through a resistor from class by applying conservation of energy to a circuit. In a circuit with a switch  $S$ , resistor  $R$ , and battery  $V$ , the capacitor  $C$ , charges according to equation 2.1

$$Q(t) = Q_{max} \left(1 - e^{-\frac{t}{\tau}}\right) \quad (2.1).$$

Removing the battery  $V$  from the circuit and connecting the resistor  $R$  to the capacitor  $C$ , the capacitor discharges following equation 2.2.

$$Q(t) = Q_{max} e^{-\frac{t}{\tau}} \quad (2.2).$$

Experimentally it is difficult to measure the charge that is flowing onto the plates of the capacitor as it charges or discharges. Charging or discharging the capacitor produces a potential difference across the plates of the capacitor and this potential difference is related to the charge by by equation 2.3.

$$Q = CV \quad (2.3),$$

where  $C$  is the capacitance of the system. Therefore, the charging and discharging equations may be written in terms of the potential differences across the capacitor as functions of time. For the charging capacitor we have

$$V(t) = V_{max} \left(1 - e^{-\frac{t}{\tau}}\right) \quad (2.4),$$

while for the discharging capacitor

$$V(t) = V_{max} e^{-\frac{t}{\tau}} \quad (2.5).$$

In the resistor-capacitor circuit, there is a characteristic time it takes to put approximately 63% of the charge onto (or for the potential difference across) the plates of the capacitor, or to remove 63% of the charge from (or the potential difference across) the plates of the capacitor. We call this characteristic time  $\tau$ , or the time constant of the circuit. The time constant of the circuit, whether charging or discharging, is given by the product of the resistance and capacitance of the circuit,

$$\tau = RC \quad (2.6).$$

In this laboratory experiment, we will investigate the charging and discharging of a capacitor through a resistor and the dependence of the time constant of the discharging circuit on the resistance and capacitance. The circuit that we will use to charge and discharge the capacitor is shown in Figure 2.1 below. A double-pole switch  $S$  connects the capacitor  $C$  either to a resistor  $R$  and a power supply  $V$  to charge the capacitor or it connects the resistor  $R$  and capacitor  $C$  together

to investigate the discharge of the capacitor. The resistor  $R$  is a variable resistance and can be changed throughout the experiment.

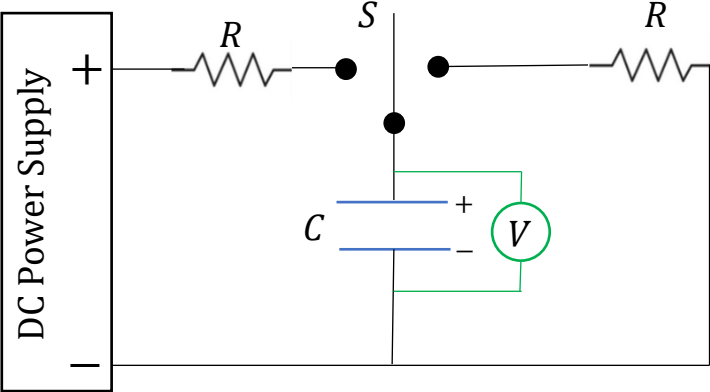

Figure 2.1: Schematic wiring diagram to study the charging and discharging of a capacitor  $C$  through a resistor  $R$ .

## Experiment #2 Resistor-Capacitor Circuits Pre-Laboratory Exercises

Read laboratory experiment #2 on the resistor-capacitor circuit, then answer the following questions in complete sentences. Be sure to print out and hand in any data and graphs you made along with the answers to these questions. The pre-laboratory exercise is due at the beginning of the laboratory period and late submissions will not be accepted.

1. A capacitor is constructed out of two parallel metal plates separated by a distance  $d = 0.5\text{mm}$ . The plates are rectangular defined by the width  $W = 25\text{cm}$  and length  $L = 250\text{cm}$ . If the plates are held apart by an insulating material with dielectric constant  $\kappa = 210$ , what is the capacitance  $C$  of the system?
2. The capacitor in question #1 is wired to a  $12\text{V}$  battery, a switch  $S$ , and an unknown resistor  $R$  shown in Figure PLE2.1. At time  $t = 0$  the switch  $S$  is closed and the capacitor  $C$  begins to charge through the resistor  $R$ . Data are taken on the potential difference  $V_C$  across the capacitor as a function of time  $t$  and the data are given in table PLE2.1 below. Plot the data of the potential difference  $V_C$  across the capacitor (on the y-axis) as a function of time  $t$  (on the x-axis).

$t$ (s)	$V_C$ (V)
0	0.00
10	1.84
20	3.40
30	4.72
40	5.84
50	6.78
60	7.59
70	8.26
80	8.84
90	9.32
100	9.73
110	10.08
120	10.38
130	10.63
140	10.84
150	11.01
160	11.17
170	11.29
180	11.40
190	11.49
200	11.57

Table PLE2.1: Potential difference across a capacitor  $C$  charging through an unknown resistor  $R$  as a function of time.

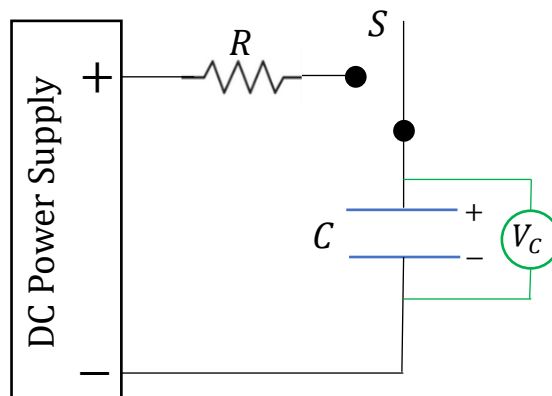

Figure PLE2.1: Schematic wiring diagram showing a capacitor  $C$  charging through an unknown resistor  $R$ .

- From the plot  $V_C$  of versus  $t$ , fit the data with an equation of the form given by equation 2.4. You will have to fit the data by hand as Excel and Google Sheets do not have equation 2.4 as a curve fit option. To do this you will need to construct your own curve fit to the data and then overlay the curve fit to the original data in the plot. Using the same times given in Table PLE2.1 and equation 2.4 determine a suitable value for  $V_{max}$  and a guess for  $\tau$ . A good value to start with is  $V_{max} = 12V$ . You may have to adjust this value to get a good fit. That's experimental uncertainty. Using your equation, generate a column of potential differences and add these data to your original data. You'll probably notice that the two curves do not overlay on top of each other. To get them to overlay and to fit the curve, you will have to adjust the value of the time constant  $\tau$ . As you change  $\tau$ , the curve will shift. Keep changing the value of  $\tau$  until you get the two sets of data to overlay each other. You may have to adjust  $V_{max}$  too. The fit to the data is good when you can no longer see any difference between the data and your curve fit. When you've achieved a good curve fit to the data, enter your equation of the fit below.

$$V_C(t) =$$

- From the curve fit to the data that you constructed, what is the time constant  $\tau$  of the resistor-capacitor circuit? Explain how you determined the time constant of the circuit and enter the value of the time constant below.

$$\tau =$$

- Using your value of the capacitance  $C$  and time constant  $\tau$ , what is the value of the unknown resistor  $R$  that was used in the charging circuit? Show your calculation and enter your value below.

$$R =$$

### ***Experimental Procedure:***

We will be using a computer program called Pasco Capstone to collect data. Open Capstone from the desktop and click hardware setup from the left-hand side of the screen. On the data collection box that appears on the screen click the large yellow circle labeled *A* and from the drop-down menu choose voltage sensor. If you get a yellow triangle after choosing voltage sensor, consult your instructor. If you get no error messages, close the hardware setup box by clicking hardware setup again.

From the choices on the screen, select sensor data and this should give you a graph of voltage (on the y-axis) and time (on the x-axis). If you don't see this screen consult your instructor. You are now ready to collect data.

### *Activity 1: Time dependence of the potential difference across the charging capacitor*

If the circuit in Figure 1 is not wired, wire it now according to the figure. Have your instructor check the circuit before you begin and **be sure to observe the polarity of the capacitor and do not set R to zero.**

Set both variable resistor boxes to a resistance of  $R = 10k\Omega$ , and wire the circuit with the blue capacitor  $C_1 = 10000\mu F = 0.01F$ . Move the double pole switch *S* to the left to connect the battery *V*, resistor *R*, and capacitor  $C_1$  together and at the same time on Capstone, click record. You should see the voltage across the capacitor changing as a function of time and it should be increasing. Collect (record) data for a time  $t = 300s$ . After a time  $t = 300s$  stop the data collection and from the curve fit choices drop-down menu select *Inverse Exponent*. This will generate a fit to your data. Record the equation of the curve fit below and print your plot.

Capacitor Charging:  $V(t) =$

### *Activity 2: Time dependence of the potential difference across the charging capacitor*

After you have printed your plot clear the data. When ready, move the double pole switch *S* to the right to connect the resistor *R* and capacitor  $C_1$  together and at the same time click record on Capstone. You should see the voltage across the capacitor changing as a function of time and it should be decreasing. Collect data for a time  $t = 300s$  and then click stop to end the data collection. From the curve fit choices drop-down menu select *Natural Exponent*. This will generate a fit to your data. Record the equation of the curve fit below and print your plot.

Capacitor Discharging:  $V(t) =$

*Activity 3: Dependence of the time constant  $\tau$  on  $R$  for a fixed  $C$ ?*

We will determine how the time constant of the circuit  $\tau$  depends on the values of the resistance  $R$  and capacitance  $C$  for a fixed value of  $C$ . Using the same blue capacitor ( $C_1 = 0.01F$ ) that you used in to charge and discharge the capacitor in activities 1 & 2, set the decade resistance box connected between the battery  $V$  and capacitor  $C$  to a value  $R_{left} = 1000\Omega$  and do not change this value for the remainder of the experiment. This will allow the capacitor to charge quickly when the battery and capacitor are connected. Now set the other resistance box to a value of  $R = 5k\Omega$ . Move the double pole switch  $S$  to the left to charge the capacitor for a time  $t = 60s$  and then move the double pole switch  $S$  to the right to connect the  $R = 5k\Omega$  resistor and  $C_1 = 0.01F$  capacitor together. At the same time as you move the switch to the right click record data on Capstone. After a reasonable amount of data has been collected, stop the data collection and from the curve fit choices drop-down menu select *Natural Exponent*. Record the equation of the fit below and determine the experimental value of the time constant of the circuit,  $\tau_{expt}$ .

$$V_{5k\Omega}(t) =$$

$$\tau_{expt,5k\Omega} =$$

Repeat the previous step setting the resistance box to the right of the double pole switch  $S$  to values of  $R = 2.5k\Omega$  and  $R = 1.25k\Omega$ . Before you make measurements, you will have to recharge the capacitor with the battery for a time  $t = 60s$ . At the same time as you move the switch to the right click record data on Capstone. After a reasonable amount of data has been collected, stop the data collection and from the curve fit choices drop-down menu select *Natural Exponent*. Record the equation of the fits below and determine the experimental value of the time constants of each of the circuits,  $\tau_{expt}$ .

$$V_{2.5k\Omega}(t) =$$

$$\tau_{expt,2.5k\Omega} =$$

$$V_{1.25k\Omega}(t) =$$

$$\tau_{expt,1.25k\Omega} =$$

Using Microsoft Excel (or the like), make a plot of the experimental values of the time constants (on the y-axis) in seconds as a function of the resistance (on the x-axis) in Ohms for the blue capacitor ( $C_1 = 0.01F$ ) and resistances  $R = 10k\Omega$ ,  $5k\Omega$ ,  $2.5k\Omega$ , and  $1.25k\Omega$ . Fit the data with a power fit and determine the equation of the fit to the data. Record your fit below and print out your data and plot. The fit should have the form  $\tau = AR^n$ , where  $A$  is the constant of proportionality and  $n$  is the exponent of  $R$ .

Equation of the fit of  $\tau$  and  $R$ :  $\tau =$

*Activity 4: Dependence of the time constant  $\tau$  on  $C$  for a fixed  $R$ ?*

We will determine how the time constant of the circuit  $\tau$  depends on the values of the resistance  $R$  and capacitance  $C$  this time for a fixed value of  $R$ . Unwire the blue capacitor from the circuit in Figure 1 and then wire the black capacitor ( $C_2 = 0.015F$ ) in its spot. Make sure that the decade resistance box connected between the battery  $V$  and capacitor  $C$  is still set to a value  $R_{left} = 1000\Omega$ . If it is not, set it to  $R_{left} = 1000\Omega$  and do not change this value for the remainder of the experiment. This will allow the capacitor to charge quickly when the battery and capacitor are connected. Now set the other resistance box to a value of  $R = 5k\Omega$ . Move the double pole switch  $S$  to the left to charge the capacitor for a time  $t = 60s$  and then move the double pole switch  $S$  to the right to connect the  $R = 5k\Omega$  resistor and  $C_2 = 0.015F$  capacitor together. At the same time as you move the switch to the right click record data on Capstone. After a reasonable amount of data has been collected, stop the data collection and from the curve fit choices drop-down menu select *Natural Exponent*. Record the equation of the fit below and determine the experimental value of the time constant of the circuit,  $\tau_{expt}$ .

$$V_{C_2}(t) =$$

$$\tau_{expt,C_2} =$$

Unfortunately, we do not have any more capacitors to wire into the circuit nor do we have a box of capacitances that we can select like we do resistances. To generate two additional value of the capacitance we will wire the blue and black capacitors together in series and parallel.

Wire the blue and black capacitors in *series* by connecting the minus side of one capacitor to the plus side of the other capacitor. Have your instructor check your circuit before you take data.

Move the double pole switch  $S$  to the left to charge the capacitors wired in series for a time  $t = 60s$ . At the same time as you move the switch to the right click record data on Capstone. After a reasonable amount of data has been collected, stop the data collection and from the curve fit choices drop-down menu select *Natural Exponent*. Record the equation of the fit below and determine the experimental value of the time constant of the circuit,  $\tau_{expt}$ .

$$V_{C_{1\&2,series}}(t) =$$

$$\tau_{expt,C_{1\&2,series}} =$$

Now wire the blue and black capacitors in *parallel* by connecting the plus side of one capacitor to the plus side of the other capacitor (and minus side of one to the minus side of the other). Have your instructor check your circuit before you take data.

Move the double pole switch  $S$  to the left to charge the capacitors wired in series for a time  $t = 120s$ . At the same time as you move the switch to the right click record data on Capstone. After a reasonable amount of data has been collected, stop the data collection and from the curve fit choices drop-down menu select *Natural Exponent*. Record the equation of the fit below and determine the experimental value of the time constant of the circuit,  $\tau_{expt}$ .

$$V_{C_{1\&2,parallel}}(t) =$$

$$\tau_{expt,C_{1\&2,parallel}} =$$

Using Microsoft Excel (or the like), make a plot of the experimental values of the time constants (on the y-axis) in seconds as a function of the capacitance (on the x-axis) in Farads for the resistance ( $R = 5000\Omega$ ) and capacitances  $C_1 = 0.01F$ ,  $C_2 = 0.015F$ ,  $C_{1\&2,series}$ , and  $C_{1\&2,parallel}$ . To construct this plot, you need values for  $C_{1\&2,series}$  and  $C_{1\&2,parallel}$ . For the moment assume that  $C_{1\&2,series} = 6000\mu F = 0.006F$  and  $C_{1\&2,parallel} = 25000\mu F = 0.025F$ . Eventually, we will have to come up with a way to verify these results. Fit the data with a power fit and determine the equation of the fit to the data. Record your fit below and print out your data and plot. The fit should have the form  $\tau = BC^m$ , where  $B$  is the constant of proportionality and  $m$  is the exponent of  $C$ .

Equation of the fit of  $\tau$  and  $C$ :  $\tau =$



### ***Data Analysis & Post-Laboratory Exercises***

Based on your data collected, graphs generated, and equations of fits to the data, answer the following questions. Be sure to print out and hand in your data and graphs along with the answers to these questions.

#### *Activity 1: Charging the capacitor*

1. From the plot of the data of the potential difference across the charging capacitor as a function of time, what is the equation of the fit to the data? Do the data taken support the form of the charging capacitor given in equation 2.4? Explain.

2. From the equation of the fit to the data of the potential difference across the charging capacitor as a function of time, what is the value of the time constant for the circuit,  $\tau_{expt}$ ?

$$\tau_{expt} =$$

3. Calculate the theoretical value of the time constant,  $\tau_{theo}$  from equation 2.6, for the circuit and show the calculation below and calculate a percent difference.

$$\tau_{theo} =$$

4. From your printed plot of the potential difference across the charging capacitor as a function of time, at what time does the potential difference equal 63% of  $V_{max}$ ? How does this compare to the time constant of the circuit from your curve fit and from the calculation. Explain your result.

5. On the set of axes below, what is the approximate shape of the potential difference across the **resistor** as a function of time as the capacitor charges. Make sure you label the axes with some numbers and that the shape has the correct form. What is the form of the equation that describes how the potential difference across the resistor changes as a function of time?



*Activity 2: Discharging the capacitor*

1. From the plot of the data of the potential difference across the capacitor as a function of time, do the data support the discharge according to equation 2.4? Explain.

2. From the equation of the fit to the data of the potential difference across the discharging capacitor as a function of time, what is the value of the time constant for the circuit,  $\tau_{expt}$ ?

$$\tau_{expt} =$$

3. Calculate the theoretical value of the time constant,  $\tau_{theo}$ , based on equation 2.6 for the circuit and show the calculation below and calculate a percent difference.

$$\tau_{theo} =$$

4. From your printed plot of the potential difference across the discharging capacitor as a function of time, at what time does the potential difference equal 37% of  $V_{max}$ ? How does this compare to the time constant of the circuit from your curve fit and from the calculation. Explain your result.

*Activity 3: Dependence of the time constant  $\tau$  on  $R$  for a fixed  $C$ ?*

1. From your plot of the time constant,  $\tau$ , as a function of the circuit resistance  $R$ , what is the equation of the fit? Print out your plot and attach it to this report or insert it into the space below.

$$\tau = AR^n =$$

What does the constant of proportionality  $A$  equate to in the equation? Calculate a percent difference.

What is the exponent of  $R$ ,  $n$ , and what is it supposed to be according to theory? Calculate a percent difference.

*Activity 4: Dependence of the time constant  $\tau$  on  $C$  for a fixed  $R$ ?*

1. From your plot of the time constant,  $\tau$ , as a function of the circuit capacitance  $C$ , what is the equation of the fit? Print out your plot and attach it to this report or insert it into the space below.

$$\tau = BC^m =$$

What does the constant of proportionality  $B$  equate to in the equation? Calculate a percent difference.

What is the exponent of  $C$ ,  $m$ , and what is it supposed to be according to theory? Calculate a percent difference.

