

Experiment #3: Ohm's Law, Series and Parallel Resistor Circuits, and Non-Ohmic Devices

Introduction: This experiment is designed to investigate the relationship between current and potential difference in series and parallel resistor circuits using the ideas of conservation of energy and charge. In a circuit containing a device (a resistor), the amount of current that can be produced by a battery is directly related to the potential difference of the battery. This is quantified in equation 3.1 and is called Ohm's law.

$$V = IR. \quad (3.1)$$

The proportionality constant in equation 3.1 is called the resistance of the circuit and is measured on Ohms. Resistance is a property of the conductor, and we can wire resistors in combinations called series and parallel. The resistance of a resistor is given by equation 3.2

$$R = \frac{\rho L}{A} \quad (3.2)$$

where ρ is the resistivity of the material (which considers the mass m and charge e of the charge carriers in the conductor, the number density of charge carriers in the conductor n , as well as the average time τ between collisions between the charge carriers with other charge carriers or nuclei), the length of the conductor L and the conductor's cross-sectional area A .

In a series circuit containing two resistors R_1 and R_2 shown in Figure 3.1 the current that enters from say the left side of resistor R_1 must flow through R_1 to resistor R_2 and then on to the right of R_1 . There is only one path for the current to flow in series, so there is only one current that can flow through the combination. Applying conservation of energy and charge, we find that the equivalent resistance for resistors in series is determined according to

$$R_{eq} = R_1 + R_2. \quad (3.3)$$

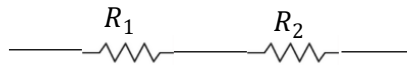

Figure 3.1: Two resistors R_1 and R_2 wired in series.

In equation 3.3 we see that the equivalent resistance R_{eq} of the combination of resistors R_1 and R_2 is greater than either R_1 or R_2 . This is based on the equation 3.3, where the effective length of the combination of resistors has increased and thus the effective resistance of the combination increases.

In a parallel circuit containing two resistors R_1 and R_2 shown in Figure 3.2 the current that enters the has a choice of where it can go. Some of the current will flow down the wire that leads to the left side of resistor R_1 and must flow through R_1 . The current that does not flow through R_1 , will flow instead to the left side of resistor R_2 and then must flow through R_2 . Applying conservation of energy and charge to the parallel circuit, we find that the equivalent resistance for resistors in parallel is determined according to

$$\frac{1}{R_{eq}} = \frac{1}{R_1} + \frac{1}{R_2}. \quad (3.4)$$

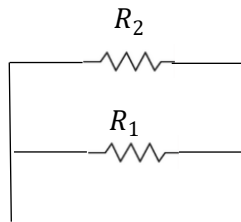

Figure 3.2: Two resistors R_1 and R_2 wired in parallel.

To measure the electrical potential difference across an element in a circuit, a voltmeter is put across its terminals. In other words, the voltmeter is connected in *parallel* with the circuit element. The internal resistance of the voltmeter is huge compared to the resistance of the circuit element being measured and since elements in parallel have the same potential differences a small amount of current goes to the meter, enough for the meter to make a measurement. The remaining (larger amount) of current passes through the circuit element.

To measure the current flowing through a circuit element an ammeter must be inserted in *series* with the element where the current must flow through the ammeter to be measured. The ammeter has a negligible resistance and thus does not affect the total circuit resistance. However, one should be careful to never insert the ammeter in parallel around the circuit element. In parallel the ammeter will have essentially the entire current pass through it blowing the fuse in the meter. Since elements in parallel have the same potential differences, the lower resistance element will get the greater share of the current. In this case it will be the ammeter. On a similar note, one should take care not to wire the voltmeter in series with the circuit element, not because you will hurt the meter, but because the resistance of the meter is so large in voltmeter setting that a negligible current will be drawn from the power supply.

The voltage source in this experiment is an electronic power supply whose output voltage can be varied from zero to about 30 volts. You will measure current and voltages with a digital multimeter or DMM, so called because this versatile measurement device can measure several electrical properties, including voltage, current and resistance.

Experiment #3 Ohm's Law, Series & Parallel Resistor Circuits, & Non-Ohmic Devices Pre-Laboratory Exercises

Read laboratory experiment #3 on Ohm's Law, Series & Parallel Resistor Circuits, & Non-Ohmic Devices, then answer the following questions in complete sentences. Be sure to print out and hand in any data and graphs you made along with the answers to these questions. The pre-laboratory exercise is due at the beginning of the laboratory period and late submissions will not be accepted.

1. An unknown resistor R is connected in series to a $R_1 = 100\Omega$. This combination of resistors is connected to a variable potential battery V and a current I is produced as is shown in Figure PLE3.1. Data are taken on the potential difference across the resistors V_{R,R_1} as a function of the total current I through the combination of resistors R and R_1 , as the battery potential V is varied. The current is measured on the ammeter A , and the data are given in Table PLE3.1. Make a plot of the potential difference across the resistors V_{R,R_1} (on the y-axis) versus the total current I through the resistors (on the x-axis). From a curve fit to the data, determine the slope of the plot. Using the slope of the plot, determine the value of the unknown resistance R . Show your calculations and enter the results below.

$V_{R,R_1} (V)$	$I (mA)$
0.98	5.70
1.97	11.45
3.01	17.50
4.1	23.84
5.2	30.23
5.98	34.77
7.1	41.28
8.04	46.74
9.15	53.20
9.99	58.08

Table PLE3.1: Potential difference the combination of resistors R and R_1 as a function of the current through the resistors I .

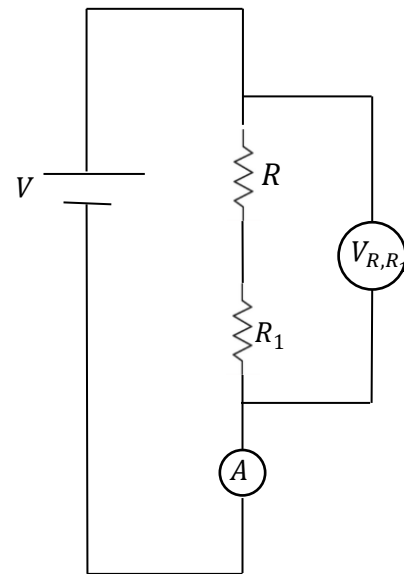

Figure PLE3.1: Schematic of the setup for measuring the potential difference the combination of resistors R and R_1 as a function of the current through the resistors I .

Slope of the V_{R,R_1} versus I plot: $slope =$

Value of unknown resistance: $R =$

2. An unknown resistor R is connected in parallel to a $R_1 = 100\Omega$. This combination of resistors is connected to a variable potential battery V and a current I is produced as is shown in Figure PLE3.2. Data are taken on the potential difference across the resistors $V_{R,R1}$ as a function of the total current I through the combination of resistors R and R_1 , as the battery potential V is varied. The current is measured on the ammeter I_t , and the data are given in Table PLE3.2. Make a plot of the potential difference across the resistors $V_{R,R1}$ (on the y-axis) versus the total current I through the resistors (on the x-axis). From a curve fit to the data, determine the slope of the plot. Using the slope of the plot, determine the value of the unknown resistance R . Show your calculations and enter the results below.

$V_{R,R1}(V)$	$I(mA)$
0.98	17.64
1.97	35.46
3.01	54.18
4.1	73.8
5.2	93.6
5.98	107.64
7.1	127.8
8.04	144.72
9.15	164.7
9.99	179.82

Table PLE3.2: Potential difference the combination of resistors R and R_1 as a function of the total current produced by the battery V .

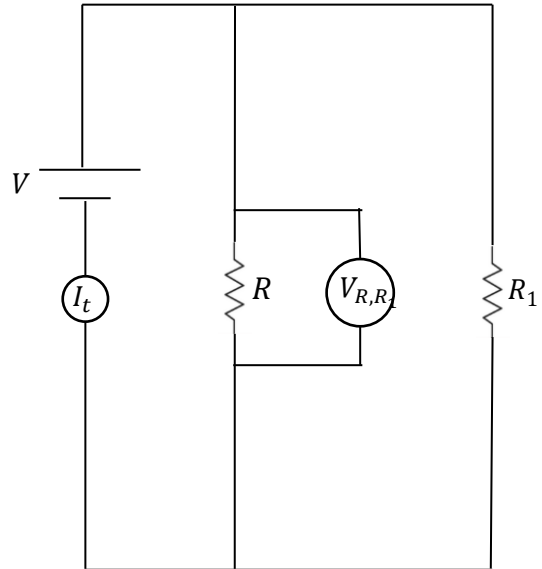

Figure PLE3.2: Schematic drawing of the potential difference the combination of resistors R and R_1 as a function of the total current produced by the battery V .

Slope of the $V_{R,R1}$ versus I plot: *slope* =

Value of unknown resistance: R =

Experimental Procedure:

Activity 1: Determining the resistance of a resistor

1. Three resistors are supplied, and their nominal values are $R_1 = 220\Omega$, $R_2 = 330\Omega$, and $R_3 = 470\Omega$. Record their actual resistances using the DMM provided. The resistors will simply plug into the DMM in the *COM*/ Ω terminals. Be sure to set the DMM to measure resistance.

$$R_{1,actual} =$$

$$R_{2,actual} =$$

$$R_{3,actual} =$$

2. For each resistor you have, wire it in a circuit as shown in Figure 3.3. make sure the DMM that is used as an ammeter is wired in series and that the DMM used to measure voltage is wired in parallel. Have your instructor check your circuit before you turn anything on.

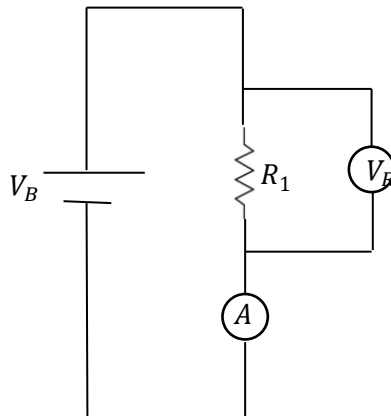

Figure 3.3: Wiring diagram for a single resistor connected to a battery V_B . The voltmeter is placed in parallel across the resistor R to measure the potential difference across the resistor V_R while the ammeter A is placed in series to measure the current I that flows through the resistor.

3. Select 10 potential differences on the power supply (V_B) and measure the corresponding potential difference across the resistor (V_R) and the current (I) through the resistor as measured on each of the DMM's.
4. Construct a plot of the potential difference across the resistor V_R on the y-axis versus the current I through each resistor on the x-axis. Plot the data for all three resistors on the same graph.

- If the data are linear, fit the data with a straight line and determine the experimental values of the resistance for each resistor and record the values below.

$$R_{1,expt} =$$

$$R_{2,expt} =$$

$$R_{3,expt} =$$

Activity 2: The Series Circuit

- Choosing resistors R_1 and R_2 , wire the series circuit as shown in Figure 3.4. You will need 3DMM's for this part of the experiment and make sure to wire the ammeter in series and the two voltmeters in parallel. Before you turn on the power supply, have your instructor check your circuit.

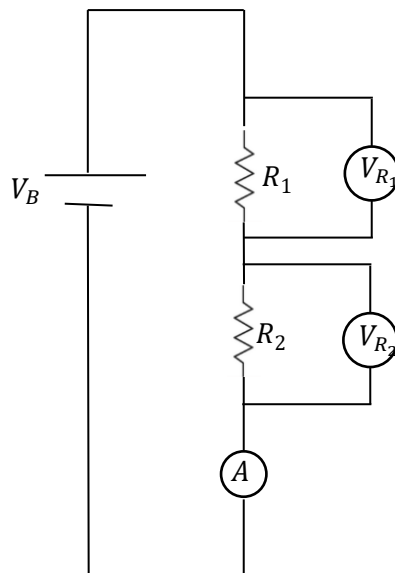

Figure 3.4: Wiring diagram for two resistors wired in series and connected to a battery V_B . Each voltmeter is placed in parallel around the resistor R to measure the potential difference across the resistor V_R while the ammeter A is placed in series to measure the current I that flows through the resistor combination.

- Set a potential difference $V_B = 2V$ for the battery and determine the current through each resistor by using the DMM in ammeter mode. Record the value of the constant total current for the $V_B = 2V$ power supply in Table 3.1 below.

- For power supply potentials, V_B ranging from $4V$ to $10V$ in $2V$ increments, measure the total current I_{total} in the circuit produced by the battery and measure the potential differences V_{R_1} and V_{R_2} across resistors R_1 and R_2 respectively for each battery potential. Record your values in Table 3.1 below.

$V_B (V)$	$V_B (V)$	$V_{R_1} (V)$	$V_{R_2} (V)$	$I_{total} (A)$
$2V$				
$4V$				
$6V$				
$8V$				
$10V$				

Table 3.1: Data table for two resistors in series.

- Construct a plot of V_B , V_{R_1} , and V_{R_2} versus the total current I_{total} for each battery voltage on the same graph.
- You should have three lines on this plot. If the data are linear, fit each line with a straight line and record the equation of the fit below.

Equation of the fit for V_B : $V_B =$

Equation of the fit for V_{R_1} : $V_{R_1} =$

Equation of the fit for V_{R_2} : $V_{R_2} =$

Activity 3: The Parallel Circuit

1. Choosing resistors R_1 and R_2 , wire the series circuit as shown in Figure 3.5. You will need 4DMM's for this part of the experiment. Three of the DMM's will be used to measure the currents in the circuit and the last DMM will be used to measure the potential difference across the resistors and power supply by simply moving the leads of the DMM.

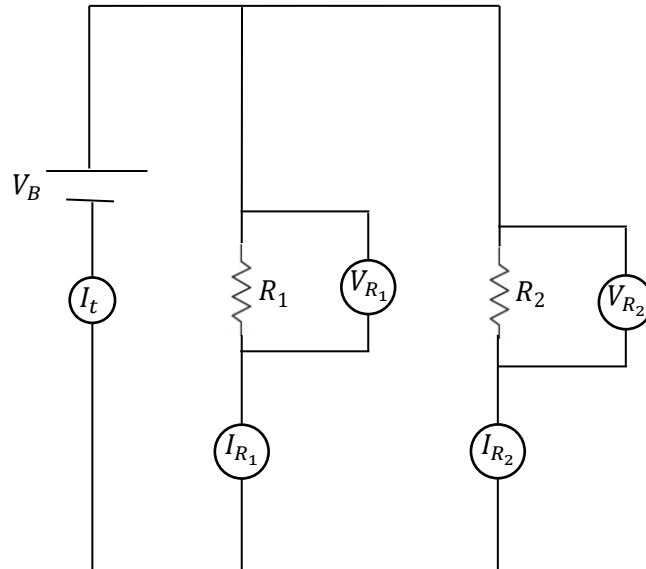

Figure 3.5: Wiring diagram for two resistors wired in parallel and connected to a battery V_B . The voltmeter is placed in parallel around each resistor R to measure the potential difference across the resistor V_R while ammeters are placed in series after each resistor to measure the current I that flows through a given resistor as well as one to measure the total circuit current I_t .

2. Set a potential difference $V_B = 2V$ for the battery and determine the current through each resistor I_{R_1} and I_{R_2} for resistors R_1 and R_2 respectively and the total current I_t by using the DMM in ammeter mode. Record the value of the constant total current for the $V_B = 2V$ power supply in Table 3.2 below.

V_B (V)	V_B (V)	I_t (A)	V_{R_1} (V)	I_{R_1} (A)	V_{R_2} (V)	I_{R_2} (A)
2V						
4V						
6V						
8V						
10V						

Table 3.2: Data table for two resistors in parallel.

- For power supply potentials, V_B ranging from $4V$ to $10V$ in $2V$ increments, measure the total current I_t in the circuit produced by the battery the current through each resistor I_{R_1} and I_{R_2} for resistors R_1 and R_2 respectively. In addition, measure the potential differences across each resistor V_{R_1} and V_{R_2} across resistors R_1 and R_2 as well as the power supply potential V_B . To measure each of the potential differences, simply move the leads of the voltmeter from one device and reconnect the meter in parallel around the next device. If you are not sure how to do this, ask your instructor for help. Record your values in Table 3.2 below.
- Construct a plot of V_B versus I_t , V_{R_1} versus I_{R_1} , and V_{R_2} versus I_{R_2} on the same graph.
- You should have three lines on this plot. If the data are linear, fit each line with a straight line and record the equation of the fit below.

Equation of the fit for V_B : $V_B =$

Equation of the fit for V_{R_1} : $V_{R_1} =$

Equation of the fit for V_{R_2} : $V_{R_2} =$

Activity 4: A Compound Series and Parallel Circuit

- Using all three of your resistors, wire the compound series and parallel circuit as shown in Figure 3.6. You will need 4DMM's for this part of the experiment. You will need 4DMM's for this part of the experiment. Three of the DMM's will be used to measure the currents in the circuit and the last DMM will be used to measure the potential difference across the resistors and power supply by simply moving the leads of the DMM.
- Set a battery potential difference $V_B = 5V$ and measure the total current I_t produced by the battery and the current through each resistor I_{R_1} , I_{R_2} , and I_{R_3} , using three DMMs as ammeters. Record your values in Table 3.3 below.
- Measure the potential differences across the battery V_B and each of the resistors V_{R_1} , V_{R_2} , and V_{R_3} . To measure each of the potential differences, simply move the leads of the voltmeter from one device and reconnect the meter in parallel around the next device. If you are not sure how to do this, ask your instructor for help. Record your values in Table 3.3 below.

$V_B =$	$I_t =$
$V_{R_1} =$	$I_{R_1} =$
$V_{R_2} =$	$I_{R_2} =$
$V_{R_3} =$	$I_{R_3} =$

Table 3.3: Data table for a compound series and parallel resistor circuit.

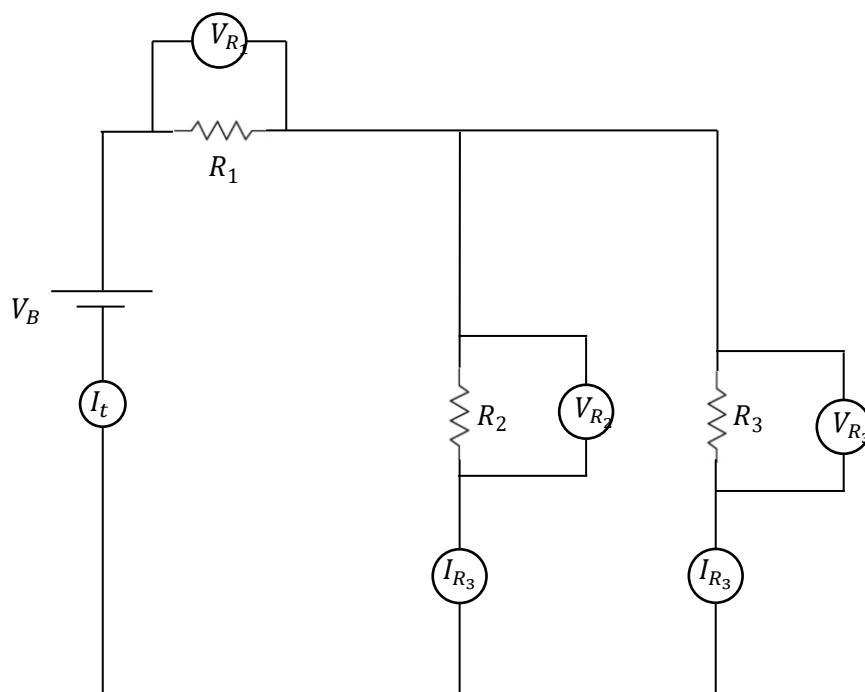

Figure 3.4: Wiring diagram for a compound circuit.

Activity 5: Deviations from Ohm's Law – Non-Ohmic devices

1. Using the light bulb and the 220Ω resistor, wire the circuit shown in Figure 3.4.
2. Set a battery potential of $1V$ and measure the potential drop across the light bulb (in V) and the current through the light bulb (in A) as measured by the two meters in the circuit. The light bulb may not light at these low voltages, but the light bulb is working if you're measuring a non-zero current through the light bulb.
3. In $1V$ increments, repeat step 2 until you reach $30V$.
4. Plot the potential difference across the light bulb on the y-axis versus the current through light bulb on the x-axis.
5. You should notice that your data do not fall on a straight line. This is because the lightbulb does not follow Ohm's law. However, you should notice that there are two portions of your plot that do look linear. Print out your plot and on the plot, draw two straight lines using a ruler through the two linear portions of the data. Determine the slopes of these two straight lines.
6. The slopes of the lines represent the resistance of the light bulb filament at low temperature and at high temperature. Calculate and record your values of the resistances $R_{low T}$ (at low values of the current when the bulb is not glowing) and $R_{high T}$ (at large currents when the bulb is glowing) for low and high temperature of the lightbulb filament below.

$$R_{low T} =$$

$$R_{high T} =$$

7. The temperature dependence of a resistance is given approximately by the formula $R_{high\ T} = R_{low\ T} [1 + \alpha(T_{high} - T_{low})]$. The parameter α is the *temperature coefficient of resistance* and the values for some materials are tabulated in your textbook. The filament in your lightbulb is made of tungsten.
8. Using $T_{low} = 20^{\circ}C$ as the approximate temperature of the room calculate the temperature of the light bulb filament when the bulb is glowing brightly and record the value below.

Temperature of the lightbulb filament when glowing: $T_{high} =$

Data Analysis & Post-Laboratory Exercises

Based on your data collected, graphs generated, and equations of fits to the data, answer the following questions. Be sure to print out and hand in your data and graphs along with the answers to these questions.

Activity 1: Determining the resistance of a resistor

1. From your graphs of V_R vs. I for the simple circuit you wired according to Figure 3.3, what are the resistances of each of the resistors (experimental)? How do they compare to the value given by the ohmmeter (theoretical)? Explain. Calculate a percent difference.

	Theoretical	Experimental	% Difference
R_1			
R_2			
R_3			

Activity 2: The Series Circuit

2. From your analysis of the series circuit, what conclusions can you draw about the ratio of the potential drop across the resistor to the current through the resistor for any given battery voltage? Is the ratio constant? Is Ohm's law valid for a resistor? Explain.

- On your graph of V_B , V_{R_1} , and V_{R_2} versus I_{total} , choose some value of the current on the x-axis and draw a vertical line. Then, for the series circuit for *any given value of the current*, what can you conclude about the current in a series circuit? Is charge conserved in the circuit? Explain.

- For the given current you drew on your graph for question 3, what can you say about the sum of the potential differences across the circuit? Do they add to the potential of the battery? Is energy conserved in the circuit? Explain.

- From this same plot of V_B , V_{R_1} , and V_{R_2} versus I_{total} for the series circuit, what can you conclude about how resistors in series add together? Explain.

6. What is the effective resistance of the series circuit $R_{expt,S}$ from your plot of V_B , V_{R_1} , and V_{R_2} versus I_t ? What is the theoretical effective resistance of the circuit $R_{theo,S}$? How do these compare? Calculate a percent difference.

Activity 3: The Parallel Circuit

7. On your graph of V_B , V_{R_1} , and V_{R_2} versus *the current through that device* for the parallel circuit choose some value of the potential on the y-axis and draw a horizontal line on the graph. Then, for the parallel circuit for *any given value of the potential difference*, what can you conclude about the current in a series circuit? Is charge conserved in the circuit? Explain.

8. For the given potential difference, you drew on your graph for question 7, what can you say about the potential differences across the circuit? Do elements in parallel have the same potential differences across them? Are the potential drops across the resistors equal to the potential of the battery? Is energy conserved in the circuit? Explain.
9. From this same plot of V_B , V_{R_1} , and V_{R_2} versus *the current through that device* for the simple parallel circuit, what can you conclude about how resistors in parallel add together?
10. What is the effective resistance of the parallel circuit $R_{expt,P}$? What is the theoretical effective resistance of the circuit $R_{theo,P}$? How do these compare? Calculate a percent difference.

Activity 4: The Compound Series and Parallel Circuit

11. From the compound series/parallel circuit, Enter the measured values from Table 3.3 below. Calculate the total current produced by the battery, the current through resistors R_1 , R_2 , and R_3 as well as the potential differences across resistors R_1 , R_2 , and R_3 and enter these values into the predicted column in the table below. Use the space below the table to do your calculations.

	Measured	Predicted	% Difference
I_{total}			
I_{R_1}			
I_{R_2}			
I_{R_3}			
V_B			
V_{R_1}			
V_{R_2}			
V_{R_3}			
R_{eq}			

12. How do the experimentally measured values of the currents and potential differences compare to the calculated values? Do your experimentally measured values correspond to what's predicted? Explain.

