

Physics 111 Homework Solutions Collected on Wednesday 10/1

Friday, September 26, 2014

Chapter 16

Questions

- 16.13 When using a multimeter as a voltmeter, the internal resistance is very large compared to what it is when it is being used as an ammeter. Placing an ammeter in parallel will damage the ammeter since its resistance is so small compared to the other resistive devices in the circuit. Given this small resistance it can be placed in series and no appreciable drop in potential will occur (and the current produced by the battery will only depend on the equivalent resistance in the circuit.) Based on Kirchhoff's rules elements in parallel experience the same potential drops across them. The amount of current that flows through elements in parallel thus only depends on the amount of resistance in the branch. For a voltmeter (with high internal resistance compared to all other resistors) placed in parallel with a resistor, both will experience the same potential drop, and the voltmeter will draw a very small current (only enough for the meter to take a reading.) Most of the circuit's current will flow through the small resistor placed in the circuit.
- 16.14 For two light bulbs placed in parallel, they experience the same potential drops across them. If they each have a resistance of R the equivalent resistance will be $R_{eq} = R/2$ and the current flow in *each branch* will be half of the total circuit current given by $V/R_{eq} = 2I$. For a single light bulb connected to a battery the total resistance is R and the circuit current is $V/R = I$. Thus the two bulbs wired in parallel each have the same current as only one bulb connected to a battery and the bulbs will be equally bright. For two bulbs connected in series this is not the case. The total resistance is $2R$ and the total circuit current is $V/2R$. Since this current is less the bulbs will not be as bright as a single bulb connected to the battery.
- 16.16 For a 150Ω equivalent resistance:
The equivalent resistance of the parallel R 's gives 50Ω and when connected in series with the last R gives an equivalent resistance of 150Ω .
For a 75Ω equivalent resistance:
For the three resistors in series they have an equivalent resistance of $3R = 300\Omega$, which when connected in parallel with the remaining R gives an equivalent circuit resistance of $3R/4 = 75\Omega$.

Multiple-Choice

- 16.1 C
16.2 C
16.3 C
16.6 C
16.8 B
16.9 C
16.10 B

16.11 C

Problems

16.6 The total resistance is the sum of the two resistances since we have two resistors wired in series. We determine the resistance of each segment from the following

$$R_{Cu} = \rho_{Cu} \frac{l_{Cu}}{A_{Cu}} = 1.7 \times 10^{-8} \Omega m \times \frac{100m}{\pi \left(\frac{1.63 \times 10^{-3} m}{2} \right)^2} = 0.82 \Omega$$

$$R_{Al} = \rho_{Al} \frac{l_{Al}}{A_{Al}} = 2.8 \times 10^{-8} \Omega m \times \frac{100m}{\pi \left(\frac{1.63 \times 10^{-3} m}{2} \right)^2} = 1.34 \Omega$$

Thus the total resistance is the sum of these two resistances, or 2.16Ω .

- The current that flows is given by Ohm's Law $I = \frac{V}{R_{total}} = \frac{6V}{2.16 \Omega} = 2.78 A$.
- The potential drops across each segment is given again by Ohm's Law. The potential drop across the copper segment is $V_{Cu} = IR_{Cu} = 2.78 A \times 0.82 \Omega = 2.27 V$ while the potential drop across the aluminum segment is $V_{Al} = IR_{Al} = 2.78 A \times 1.37 \Omega = 3.79 V$, which of course sums to the potential of the battery.
- The power dissipated across each resistor as heat is given as the product of $I^2 R$. Thus for the copper segment we have $P_{Cu} = I^2 R_{Cu} = (2.78 A)^2 (0.82 \Omega) = 6.3 W$ and for the aluminum segment $P_{Al} = I^2 R_{Al} = (2.78 A)^2 (1.34 \Omega) = 10.4 W$.

16.9 An immersible heater

For this problem we need the mass of water, $M = 4 \text{ liters} \times \frac{1 \text{ kg}}{\text{liter}} = 4 \text{ kg}$.

- The heat is given by:
 $Q = Mc\Delta T = (4 \text{ kg})(1000 \frac{\text{cal}}{\text{kg}^\circ \text{C}})(30^\circ \text{C}) = 1.25 \times 10^5 \text{ cal} = 5.02 \times 10^5 \text{ J}$.
- The power is the energy supplied per unit time:
 $P = \frac{Q}{t} = \frac{5.02 \times 10^5 \text{ J}}{1800 \text{ s}} = 278.9 \text{ W}$.
- The current is found from the power divided by the voltage drop:
 $I = \frac{P}{V} = \frac{278.9 \text{ W}}{12 \text{ V}} = 23.2 \text{ A}$.
- This is an instance of Joule heating, so the resistance can be found from:
 $R = \frac{P}{I^2} = \frac{278.9 \text{ W}}{(23.2 \text{ A})^2} = 0.52 \Omega$.

- 16.10 Given the diagram below we'll start on the right hand side combining resistors in series and parallel. We first see that resistors $5k\Omega$ and $3k\Omega$ are in series and their equivalent resistance is $8k\Omega$. Next we have three resistors in parallel, the $8k\Omega$, the $1k\Omega$ and the $4k\Omega$. The equivalent resistance of this combination is
- $$\frac{1}{R_{eq}} = \frac{1}{8k\Omega} + \frac{1}{1k\Omega} + \frac{1}{4k\Omega} = \frac{11}{8k\Omega} \rightarrow R_{eq} = 0.73k\Omega.$$
- Lastly we have from point A to point B three resistors in series. The equivalent circuit resistance is the sum of these three resistors. Thus we have $5k\Omega + 8k\Omega + 0.73k\Omega = 13.73k\Omega$.

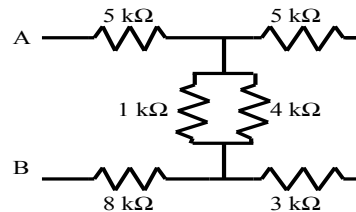

- 16.11 Here we are given a network of $1k\Omega$ resistors shown below. We'll start on the right hand side and combine resistors in series and parallel until there is only one resistor and the battery. Starting on the right we have three resistors in series and the equivalent resistance is $R_{1,eq} = 3k\Omega$. This equivalent combination is in parallel with a $1k\Omega$ resistor and the equivalent resistance is

$$\frac{1}{R_{2,eq}} = \frac{1}{3k\Omega} + \frac{1}{1k\Omega} = \frac{4}{3k\Omega} \rightarrow R_{eq} = 0.75k\Omega.$$

This combination is in series with two $1k\Omega$ resistors and the equivalent resistance of this combination is $R_{3,eq} = 2.75k\Omega$. This resistor is in parallel with a $1k\Omega$ resistor so the equivalent

resistance is $\frac{1}{R_{4,eq}} = \frac{1}{2.75k\Omega} + \frac{1}{1k\Omega} \rightarrow R_{eq} = 0.733k\Omega$. Lastly this resistor is in

series with a $1k\Omega$ resistor. The sum of these two resistors is the equivalent circuit resistance and we have $R_{eq,circuit} = 1.733k\Omega$. If this resistor is connected to a 12 V power supply the current produced is

$$I = \frac{V}{R_{eq,circuit}} = \frac{12V}{1733\Omega} = 6.9 \times 10^{-3} A = 6.9mA.$$

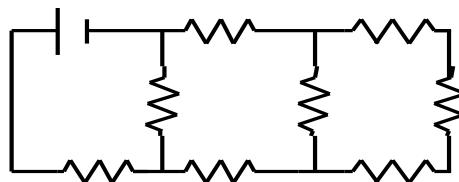

16.12 In this circuit we label the resistors as $A = 1.5k\Omega$, $B = 2.5k\Omega$, $C = 4k\Omega$ and $D = 1.5k\Omega$. Thus resistors A and B are in series and their equivalent resistance is $R_{AB} = 1.5k\Omega + 2.5k\Omega = 4k\Omega$. Equivalent resistor R_{AB} is in parallel with resistor C so the equivalent resistance of this combination is

$$\frac{1}{R_{ABC}} = \frac{1}{R_{AB}} + \frac{1}{R_C} = \frac{1}{4k\Omega} + \frac{1}{4k\Omega} = \frac{2}{4k\Omega} \rightarrow R_{ABC} = 2k\Omega.$$

Lastly equivalent resistance R_{ABC} is in series with resistor D , so the equivalent resistance is the sum of these two resistors, or $R_{ABCD} = 2k\Omega + 1.5k\Omega = 3.5k\Omega$.

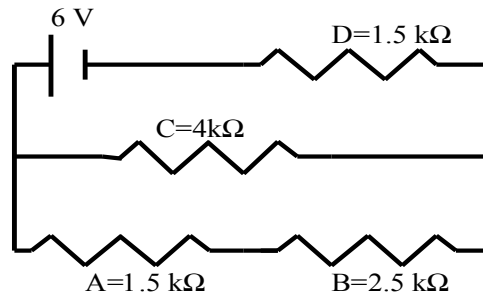

The total current produced by the battery is given by Ohm's Law

$$I = \frac{V}{R_{ABCD}} = \frac{6V}{3500\Omega} = 0.0017A = 1.7mA.$$

The current that flows through and the power dissipated by resistor D are given as $I = 1.7mA$ and $P = I^2 R_D = (0.0017A)^2 \times 1500\Omega = 0.0044W = 4.4mW$

Next this current has to flow through the equivalent combination of resistors ABC .

The potential drop across this combination is given from Ohm's Law

$$V = IR_{ABC} = 0.0017A \times 2000\Omega = 3.4V.$$

Thus across resistor C we have a $3.4V$ potential drop and current given by

$$I = \frac{V}{R_C} = \frac{3.4V}{4000\Omega} = 0.0085A = 0.85mA.$$

This current also flows through resistors A and B since their equivalent resistance is the same as resistor C .

The power dissipated across resistors A , B , and C is therefore

$$P_A = I_A^2 R_A = (0.0085A)^2 (1500\Omega) = 1.8mW$$

$$P_B = I_B^2 R_B = (0.0085A)^2 (2500\Omega) = 1.8mW$$

$$P_C = I_C^2 R_C = (0.0085A)^2 (4000\Omega) = 2.89mW$$

16.14 Given the circuit shown below we start by determining the equivalent circuit resistance. Starting at the very bottom of the circuit we have resistors A and B in series with equivalent resistance $R_{AB} = 6k\Omega$. Resistors C and D are in series with equivalent resistance $R_{CD} = 13k\Omega$. Resistors R_{AB} and R_{CD} are in parallel and the equivalent resistance of this combination is

$$\frac{1}{R_{ABCD}} = \frac{1}{R_{AB}} + \frac{1}{R_{CD}} = \frac{1}{6k\Omega} + \frac{1}{13k\Omega} \rightarrow R_{ABCD} = 4.1k\Omega.$$

Lastly we have resistor E and resistor R_{ABCD} in series and the equivalent resistance of the circuit is $R_{eq} = R_{ABCDE} = 5.1k\Omega$. The total circuit current will flow through meter A_2 and the current is $I_{A_2} = \frac{10V}{5.1k\Omega} = 2.0 \times 10^{-3} A = 2mA$. The potential drop across resistor E is given by $V_1 = IR_E = 2 \times 10^{-3} A \times 1000\Omega = 2V$. Using conservation of energy the potential drop across the remainder of the circuit is $10V - 2V = 8V$. Thus we have and $8V$ drop across resistors C and D and the current through the center branch is

$$I_{center} = \frac{8V}{13k\Omega} = 6.2 \times 10^{-4} A = 0.62mA.$$

The potential drop across the $10k\Omega$ resistor is given by $V_2 = IR_D = 6.2 \times 10^{-4} A \times 10000\Omega = 6.2V$. Further we have that the current is conserved. Thus the total circuit current is the sum of the current through the center branch and through meter A_1 . Current through meter A_1 is $I_{A_2} = I_{A_1} + I_{center} \rightarrow I_{A_1} = I_{A_2} - I_{center} = 2mA - 0.62mA = 1.38mA$.

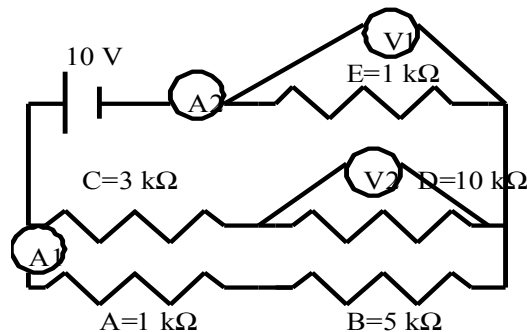

Monday, September 29, 2014

Chapter 16

Questions

- None

Multiple-Choice

- None

Problems

- None