

Rotational and Translational Statics

Example 1:

A person of mass $m_p = 70\text{kg}$ stands on the edge of a table of mass $m_t = 55\text{kg}$. How far from the right table leg can the person stand before the table tips over?

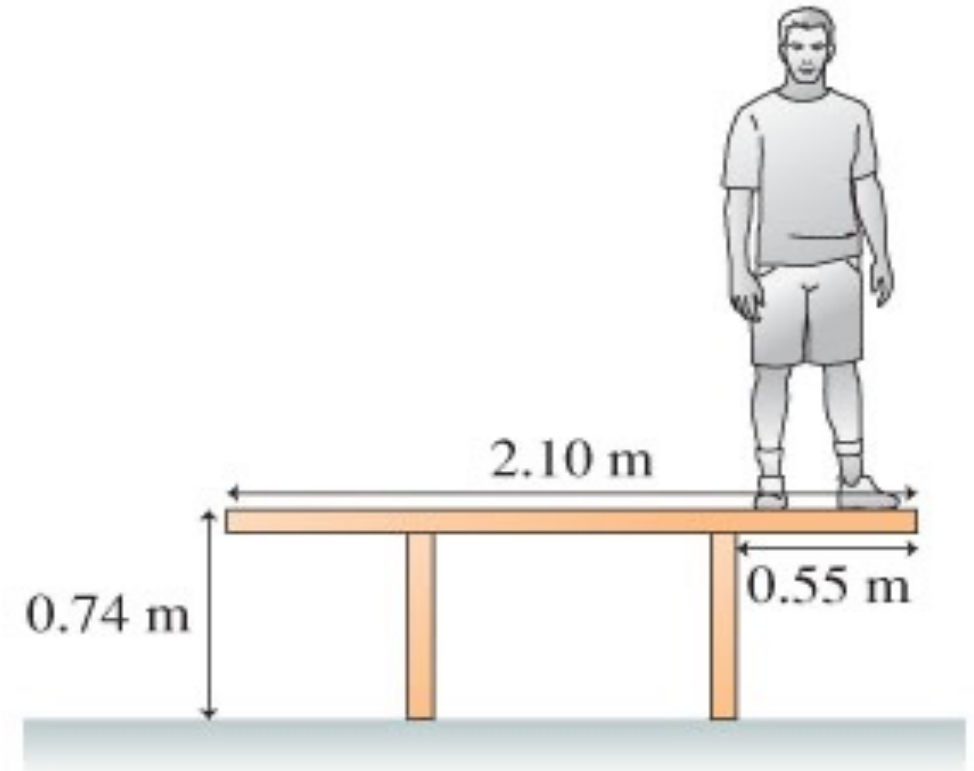
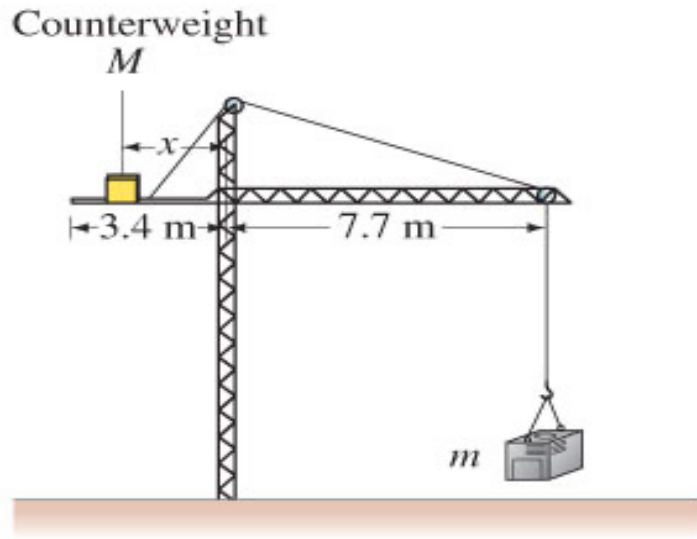

Figure from Knight, Jones and Field, Physics: A Strategic Approach, 4th Edition.

Rotational and Translational Statics

Example 2:

A tower crane must always be carefully balanced so that there is no net torque tending to tip it. A particular crane at a building site is about to lift an air-conditioning unit of mass $m_{ac} = m = 500\text{kg}$. The crane's dimensions are shown in the figure below on the right. The crane's counterweight is a movable (which provides stability against tipping) mass $m_{cw} = M = 10,000\text{kg}$ while the right and left beams have masses $m_{br} = 11,000\text{kg}$ and $m_{bl} = 10,000\text{kg}$ respectively. At what distance x from the crane's tower should the counterweight be placed so that the crane is balanced when it just picks up the air conditioner?



Rotational and Translational Statics

Example 3:

A $L = 5.0\text{m}$ long ladder with mass $m_L = 100\text{kg}$ is laid against a low friction wall at an angle ϕ measured with respect to the floor as shown on the right.

Suppose that the coefficient of friction between the floor and ladder is $\mu = 0.09$ and that a painter of mass $m_p = 60\text{kg}$ has climbed up the ladder and has made it to a point 70% of the length of the ladder when the ladder begins to slip. At what angle ϕ was the ladder placed against the wall?

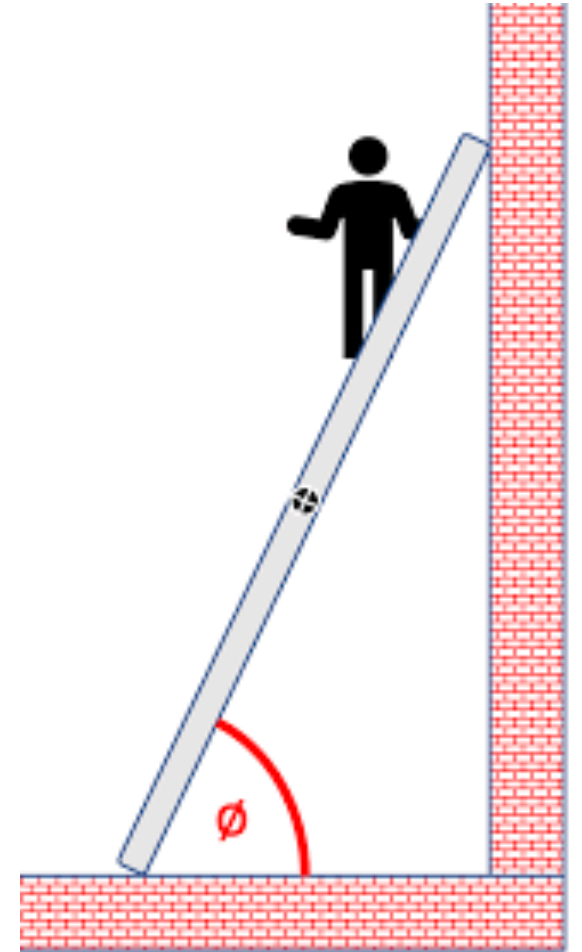

Rotational and Translational Statics

Example 4:

The Union College Physics Department has decided to hang a sign outside of the department office so that all passers by can read how much fun physics can be. Suppose that the sign (with a mass $m_s = 220\text{kg}$) is suspended by a massless wire from a uniform boom ($m_b = 110\text{kg}$) and that the boom makes an angle of $\theta = 30^\circ$ measured with respect to the vertical, as shown below. The boom is attached to the wall by a light horizontal support wire located $\frac{2}{3}$ of the way from the wall to the end of the boom.

- What is the magnitude and direction of the reaction force of the wall on the boom?
- What is the tension force in the horizontal wire?

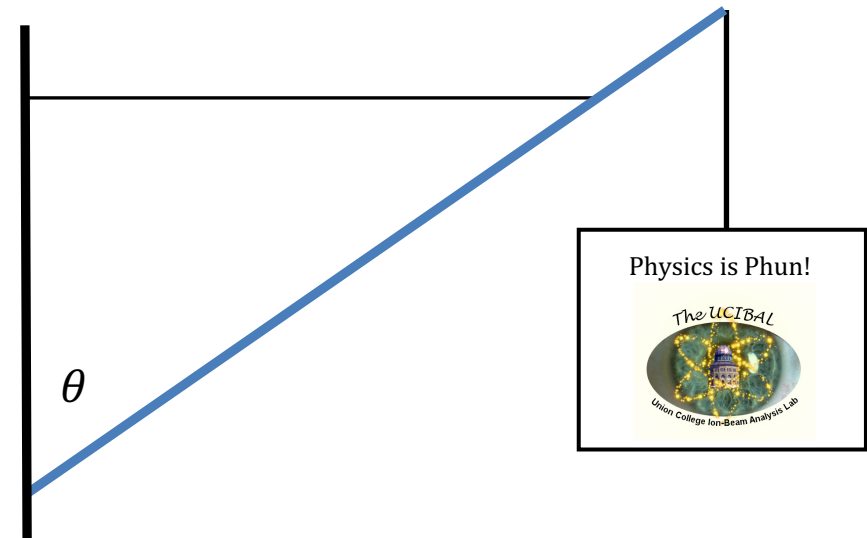

Rotational and Translational Statics

Example 5:

A person holds a 50lb weight in their hand by exerting an upward force through the bicep's tendon/muscle. What is the magnitude of the force exerted by the biceps muscle? What is the magnitude and direction of the force at the pivot, E ?

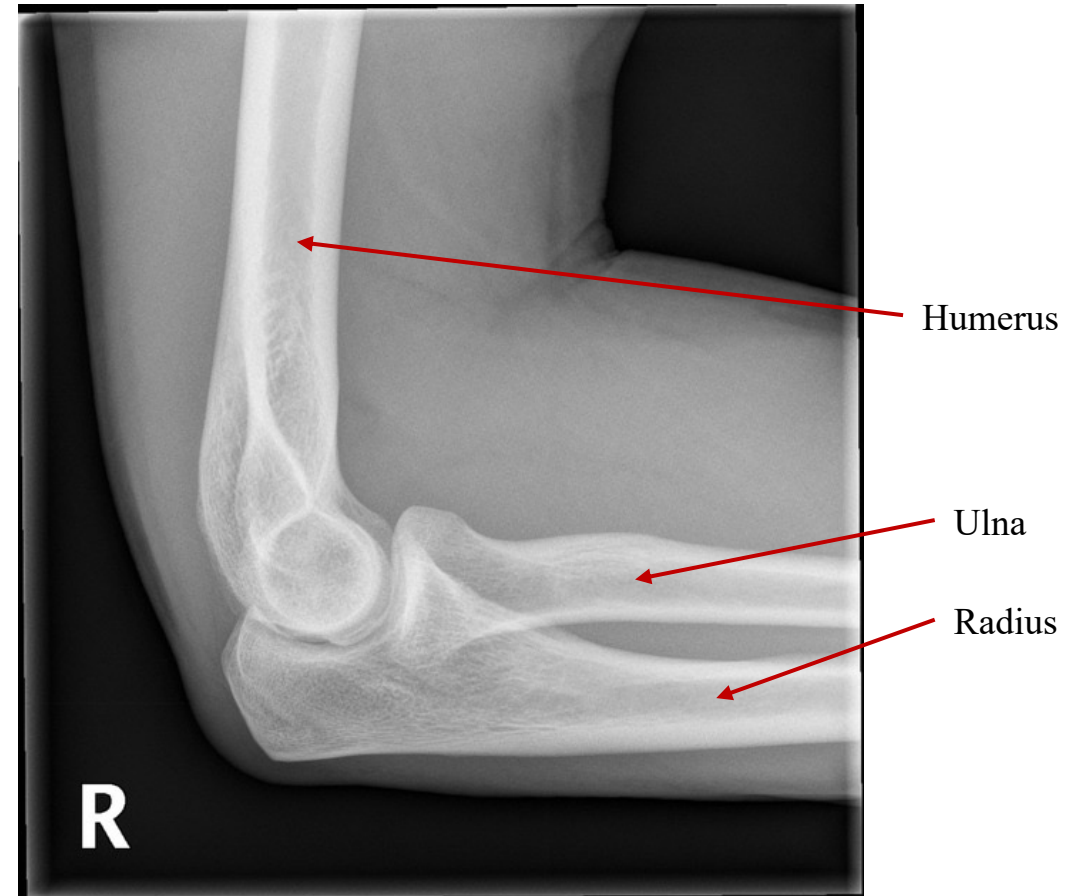
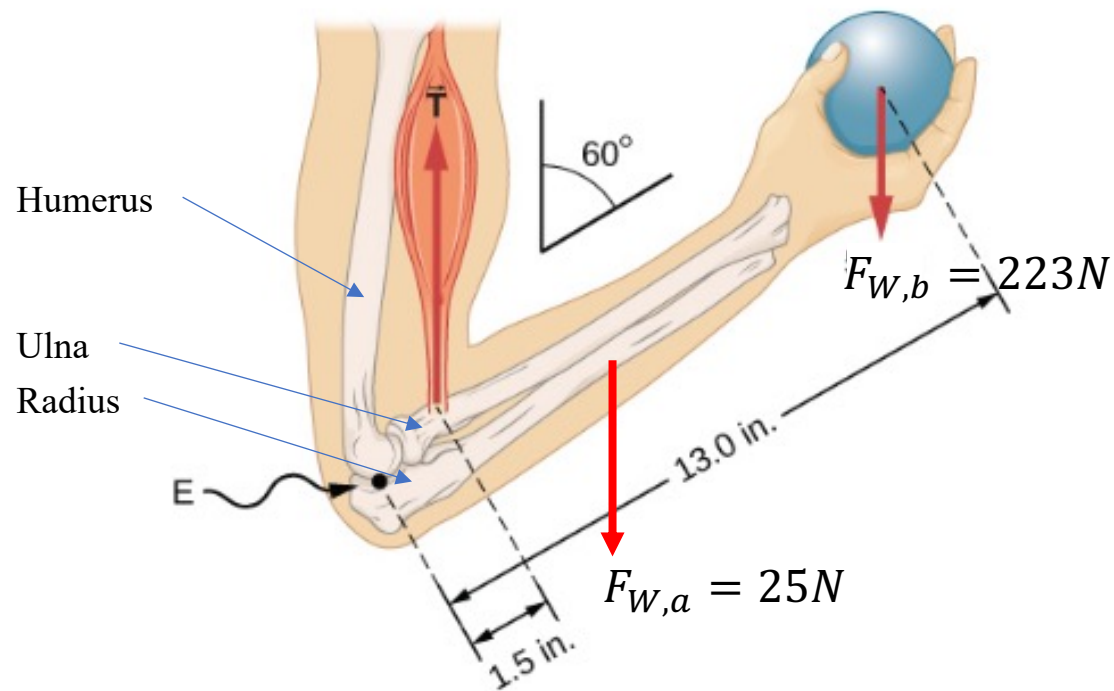

Rotational and Translational Statics

Example 6:

An 80kg person stands on their toes by exerting an upward force through their Achilles tendon. What is the magnitude of the force through the Achilles tendon? What is the magnitude of the force at the pivot, F_P ?

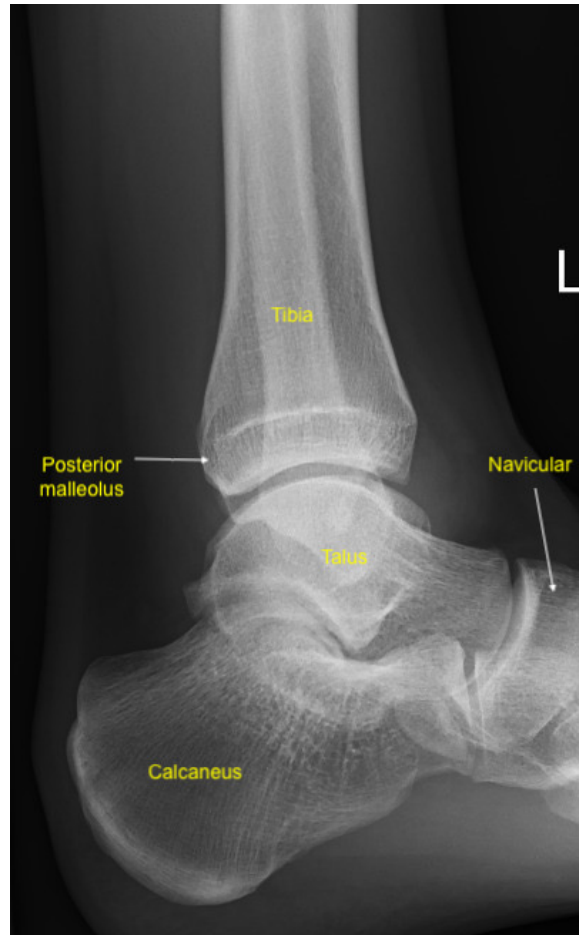

<https://www.ncbi.nlm.nih.gov/books/NBK542324/figure/article-17597.image.f3/>

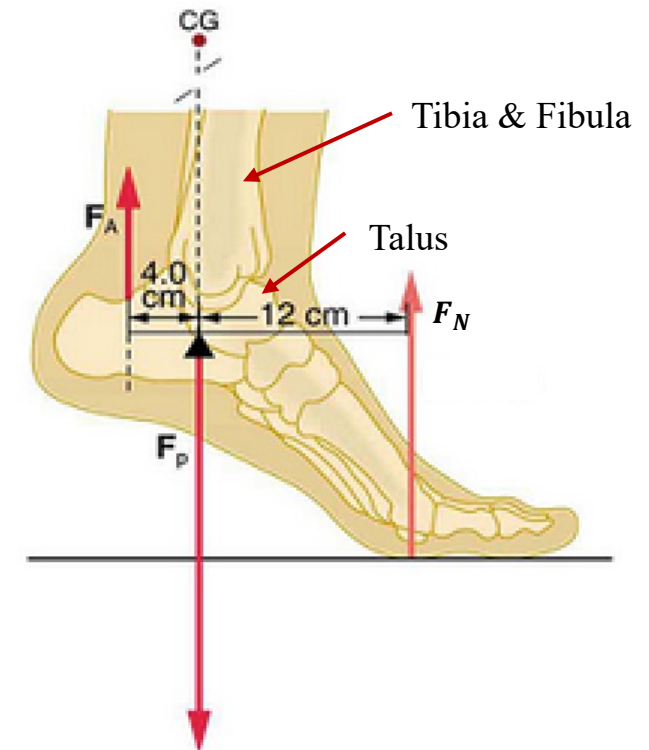

Figure are from OpenStax, University Physics Volume 1, <https://openstax.org/books/university-physics-volume-1/pages/preface>

Rotational and Translational Statics

Example 7:

As high as eighty percent of the population at one time or another will suffer from some form of lower back pain, especially during bending and lifting activities.

The stresses, which the muscles apply to the disks located between each of the vertebrae, can be very large and these stresses can, along with degeneration of the structure of the disks produce pain, muscle spasm, and immobilization of the lower back. We'll specifically look at the lumbo-sacral intersection of the spine as the point at which we bend, to say pick something up when you keep your legs straight.

We'll look at a specific case of just bending over with your arms hanging vertically to determine how large the reaction force on the lumbo-sacral disk can be in this case in terms of your weight.

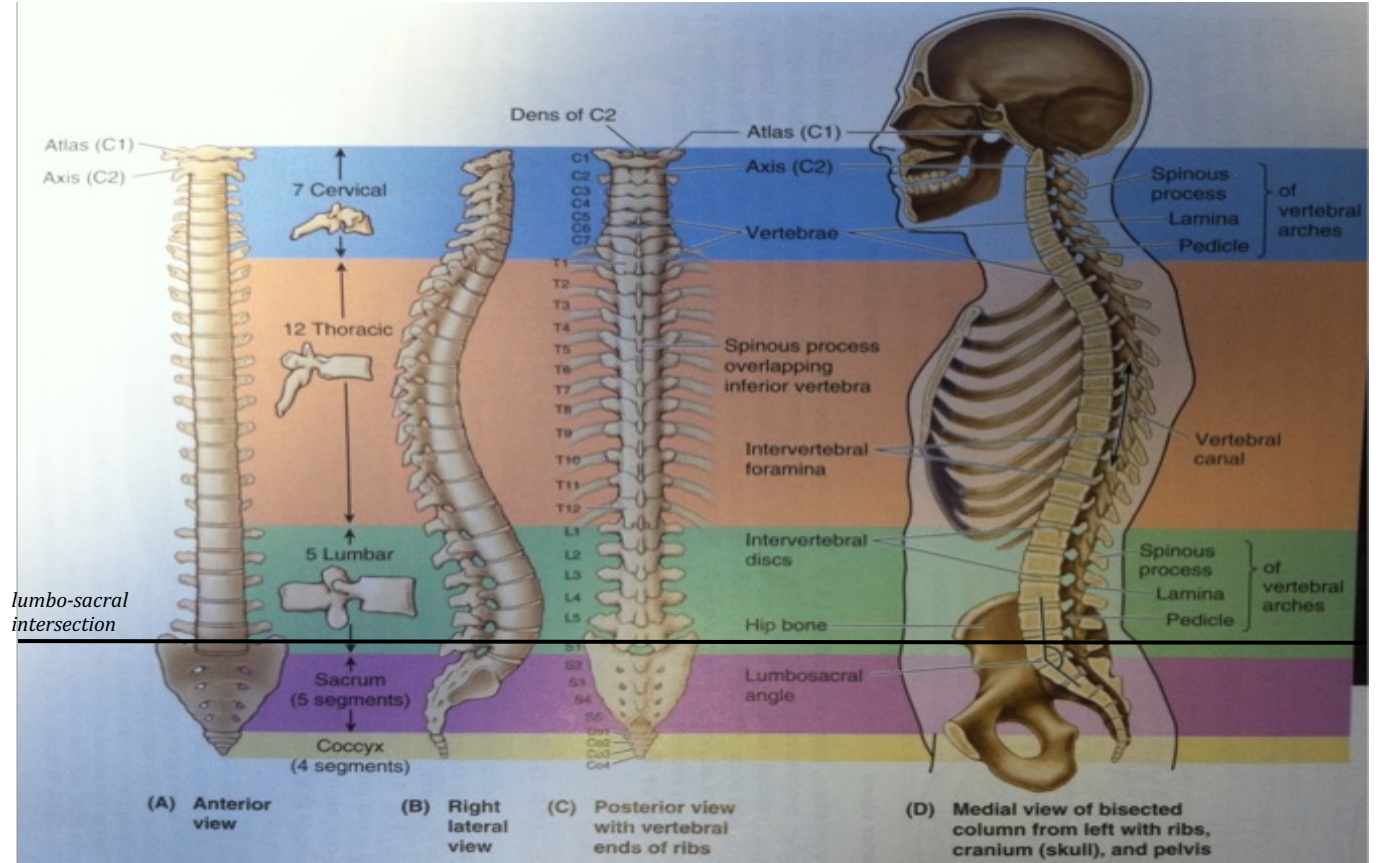

Figure 1: Views of the human spine. Figure from Clinically Oriented Anatomy, by Moore & Dalley.

Rotational and Translational Statics

- *The Major Muscle Groups and Vertebral Column of the Human Back*

Example 7:

Cadaver dissection showing the location of the *erector-spinae* muscles (stained purple for visualization).

The major muscle groups and muscles of the back are also shown.

The *erector-spinae* muscles insert at the base of the spine and run the length of your spinal column. These muscles are, in part, responsible for picking you back upright (making you erect) from a prone (or bent over) position.

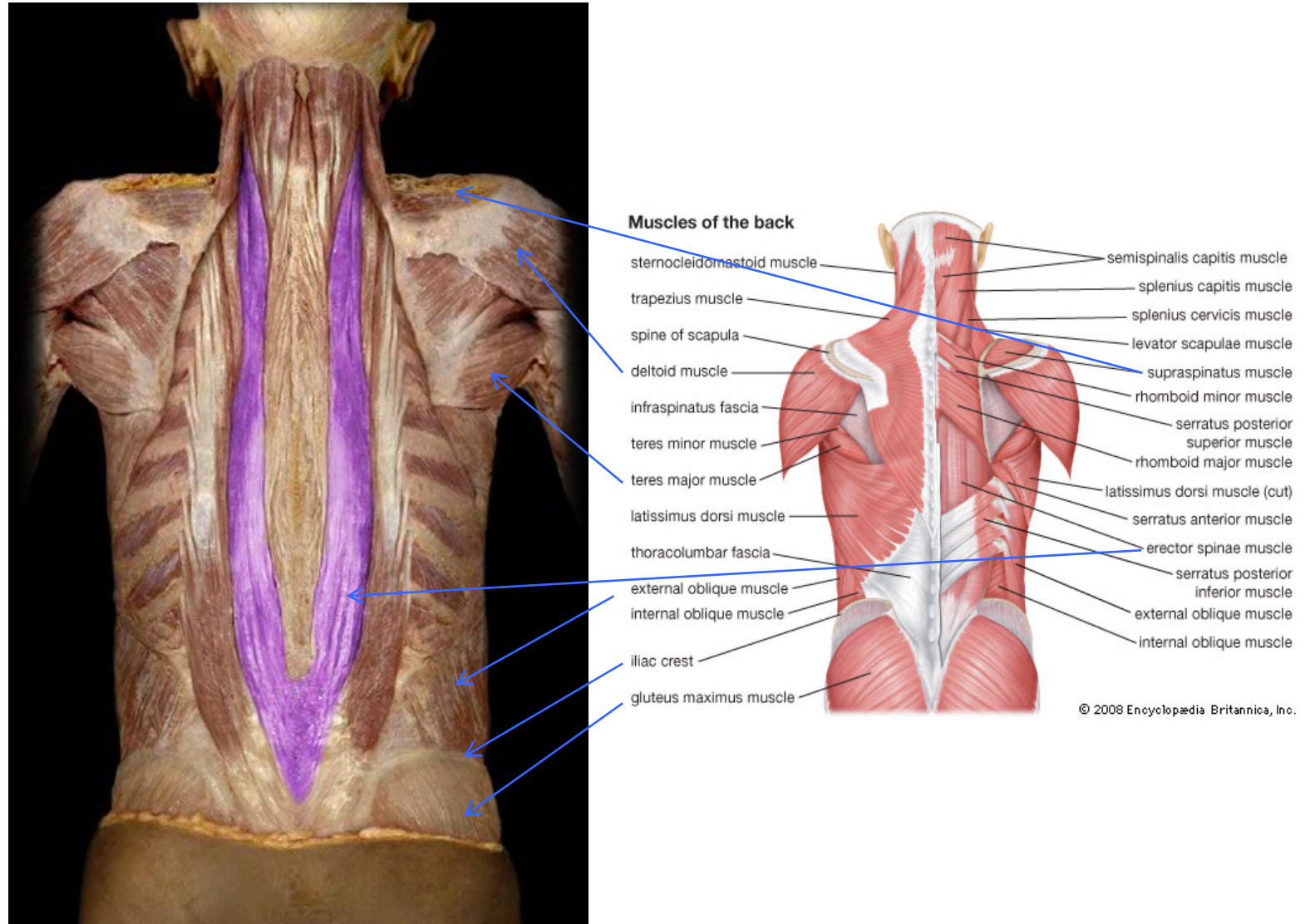

Rotational and Translational Statics

- The Major Muscle Groups and Vertebral Column of the Human Back

Example 7:

Cadaver dissection showing the location of the *erector spinae* muscles groups on either side of the spine and the vertebra of the spine.

Here it's been superimposed an x-ray image of the spine onto the back showing the erectors lie just to the side of the spinal column.

The magnetic resonance (MRI) image of the spinal column show the location of interest at the L5/S1 intersection. This is the disk (between the vertebra) that is often ruptured by lifting heavy loads incorrectly.

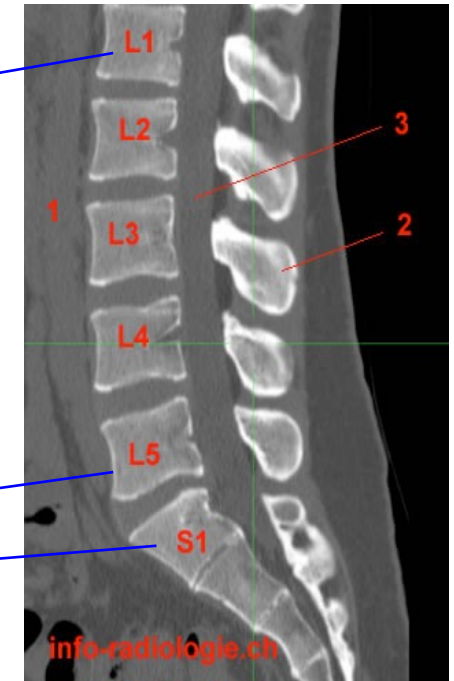
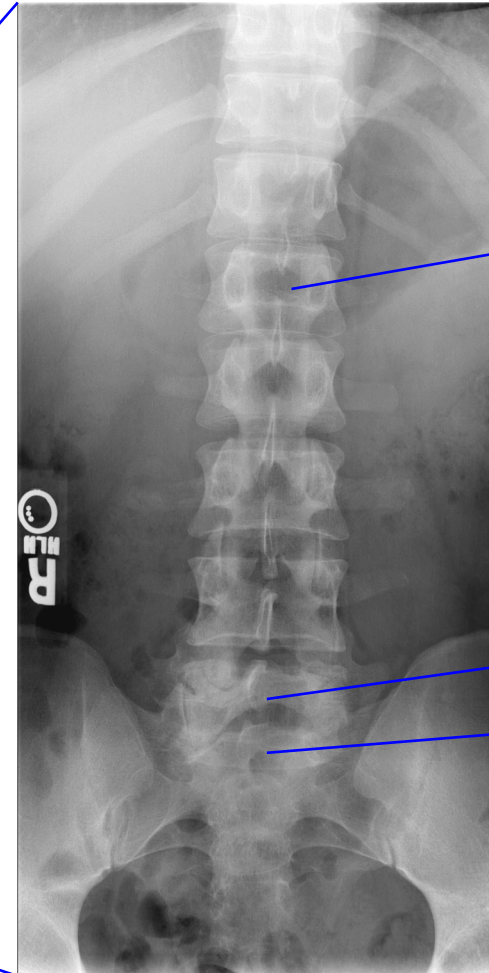

<http://w-radiology.com/ct-lumbar-spine.php>

<http://medicine.missouri.edu/radiology/iCases/MSK/case1/case01.htm>

Rotational and Translational Statics

Example 7:

- What are the expressions for the sum of the forces in the vertical and horizontal directions?
- What is the expression for the sum of the torques about the lumbo-sacral disk? We'll assume that you have bent over so that your spinal column makes an angle θ with respect to the horizontal and are not moving.
- What is the magnitude of the force F_e exerted by the *erector spinae* muscles at a point two-thirds the length (L) of your spine? Assume that $\theta = 30^\circ$, $\alpha = 12^\circ$, $F_{W,torso} = 0.5F_W$ located at $0.5L$, $F_{W,arms} = 0.1F_W$ located at $0.75L$, and $F_{W,head} = 0.07F_W$ located at L .
- What is the magnitude and direction of the reaction force F_R at the base of the spine, or at the lumbo-sacral joint, in terms of your weight F_W ?

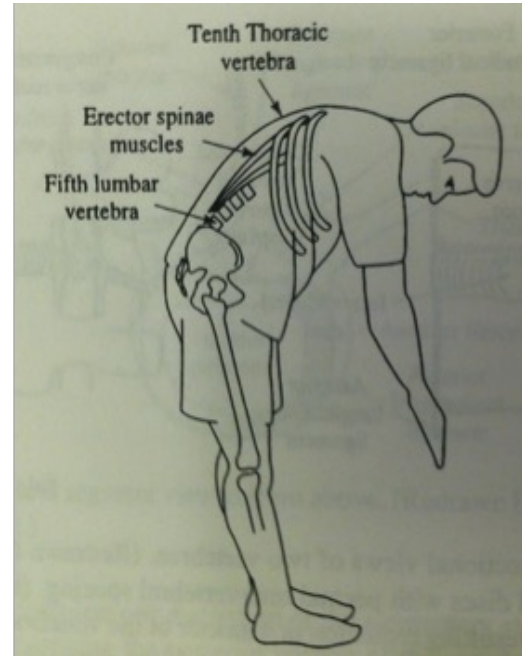

Cartoon illustration of the problem.
Drawing from *Physics with Illustrative Examples from Medicine and Biology*, by Benedek & Villars.

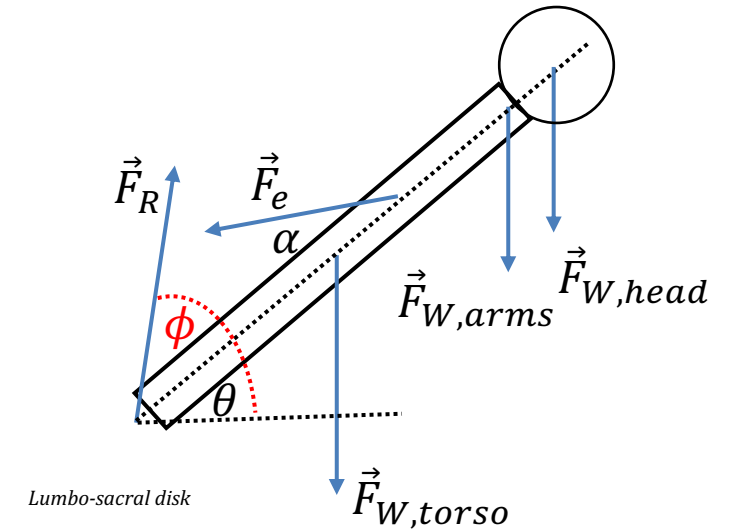

Stick figure drawing of your spinal column showing the various forces that act. The diagram is not to scale

Rotational and Translational Statics

Example 8:

- The intervertebral disk approximates a cylinder with the dimensions shown below. If the elastic modulus of the disk is $E = 25\text{MPa} = 25 \times 10^6 \frac{\text{N}}{\text{m}^2}$, by how much does the disk compress under the weight of your torso/arms/head while standing erect? Under the weight of your torso/arms/head when you're bent over? Assume you have a mass $70\text{kg} \sim 155\text{ lbs}$.

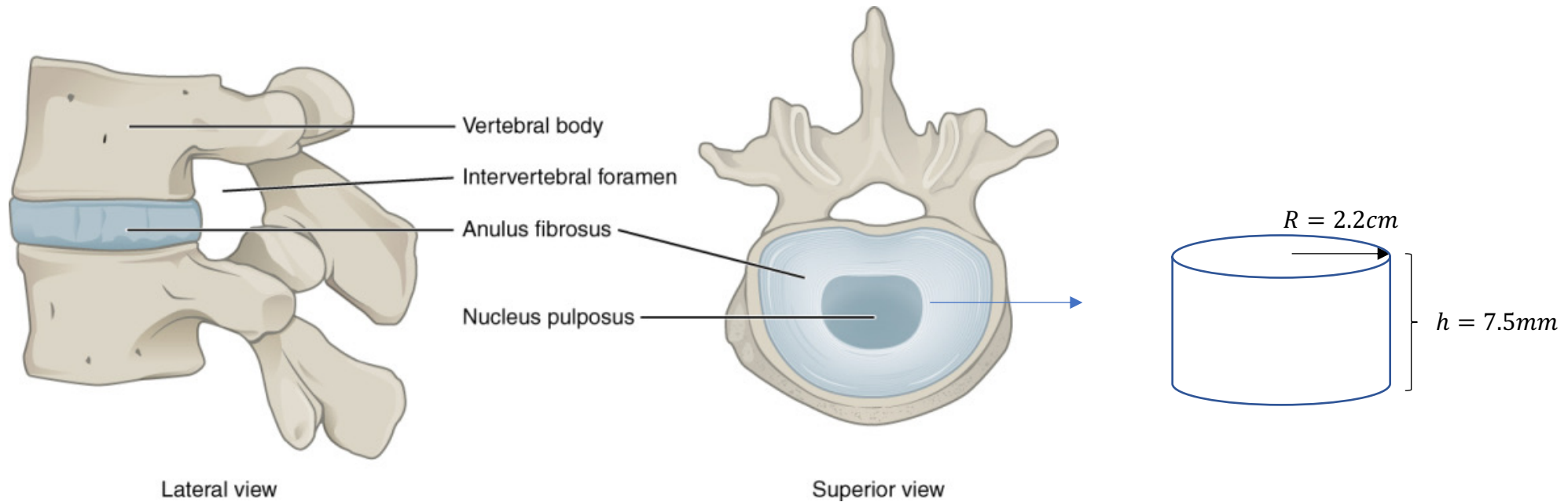

Rotational and Translational Statics

Example 1:

The Glenwood B&O Railroad Bridge in Pittsburgh Pa, that is an example of truss bridge which carries Allegheny Valley Railroad's W&P Subdivision over the Monongahela River.

The span was constructed in 1884 and upgraded in 1915. Suppose that a train engine ($F_{WE} = 220,000N$) travels across a section of this truss bridge that is $70m$ long with a weight of $F_{WB} = 230,000N$ that is supported by pylons at each end along each section of the span.

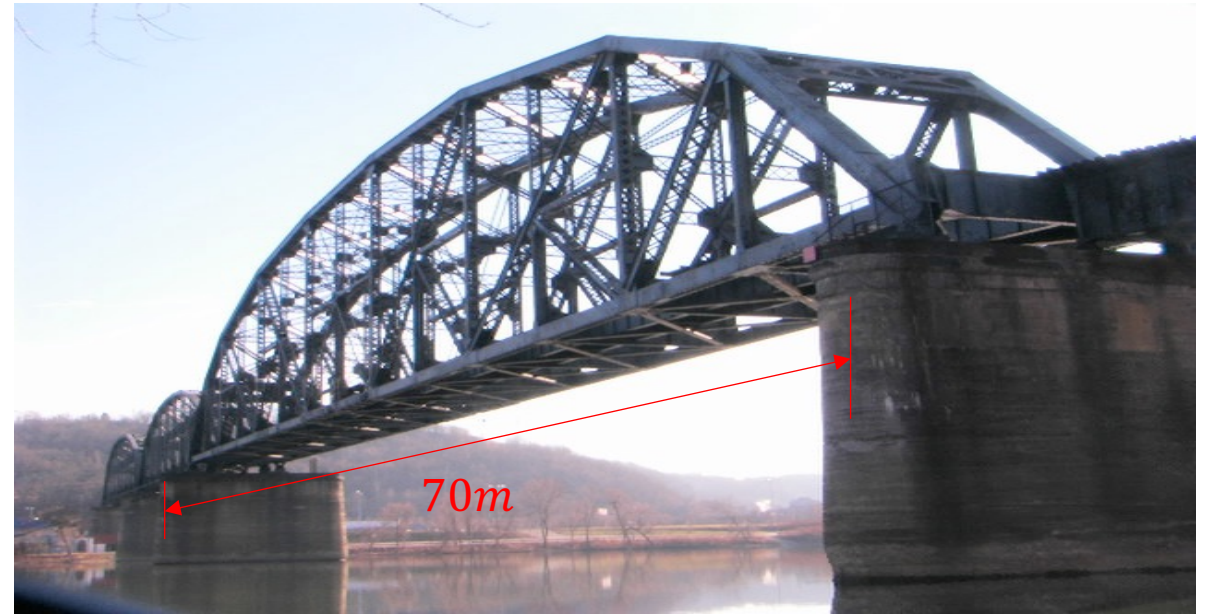

https://en.wikipedia.org/wiki/Glenwood_B%26O_Railroad_Bridge

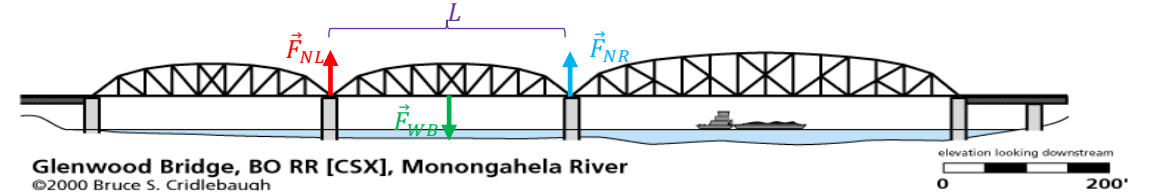

<http://pghbridges.com/pittsburghE/0590-4472/glenwoodBO.htm>

- What are the maximum and minimum forces exerted on each pylon due to the crossing when there is no train engine on the bridge?
- What are the maximum and minimum forces exerted on each pylon due to the crossing when train engine on both the left and right sides of the bridge?
- Does the location of the pivot affect these forces exerted on the pylons?