

Physics 111
Spring 2006
Uniform Circular Motion

1. The speed of the tip of the minute hand on a town clock is 1.75 mm/s.
 - a. What is the speed of the second hand if it has the same length?
 - b. What is the centripetal acceleration of the tip of the second hand?

2. Consider a conical pendulum with an 80kg bob on a 10m long wire making an angle of 5° with respect to the vertical as shown below.
 - a. What are the horizontal and vertical components of the force exerted by the wire on the pendulum?
 - b. What is the radial acceleration of the bob?

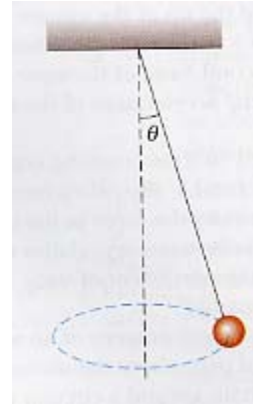

3. A 4300lb truck passes over a bump in a road that follows the arc of a circle of radius 42m.
 - a. What force does the road exert on the car as the car passes the highest point of the bump if the car is traveling at 16 m/s?
 - b. What is the maximum speed that the car can have as it passes this highest point before losing contact with the road?
4. In one model of a hydrogen atom, the electron in orbit around the proton experiences an attractive force of about 8.2×10^{-8} N. If the radius of the orbit is 5.3×10^{-11} m, how many revolutions does the electron make each second? This is called the frequency of the orbit.

5. An air puck of mass 0.250kg is tied to a string and allowed to revolve in a circle of radius 1.00m on a frictionless horizontal table as shown below. The other end of the string passes through a hole in the center of the table and a mass of 1.00kg is attached to it. The suspended mass remains in equilibrium while the puck on the tabletop revolves.
 - a. What is the tension in the string?
 - b. What is the force exerted by the string on the puck?
 - c. What is the speed of the puck?

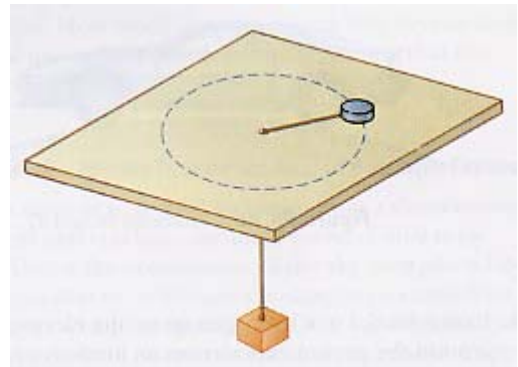

6. A child's toy consists of a small wedge that has an acute angle θ . The sloping side of the wedge is frictionless, and a mass m on it remains at constant height if the wedge is spun at a certain speed as shown below. The wedge is spun by rotating a vertical rod that is firmly attached to the wedge at the bottom end. Show that, when the mass sits a distance L up along the sloping side, the speed of the mass is $v = \sqrt{gL \sin \theta}$.

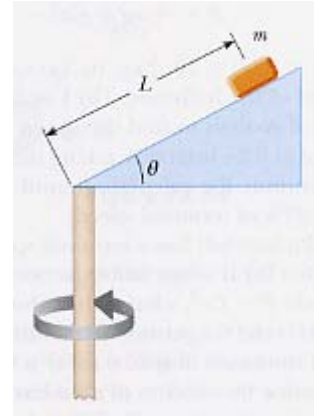

7. An amusement park ride consists of a rotating circular platform 8.0m in diameter from which 10kg seats are suspended at the end of 2.5m massless chains as shown below. When the system rotates the chains make an angle of $\theta = 28^\circ$ with respect to the vertical.
- What is the speed of each seat?
 - What does the free body diagram look like for a 40kg child riding in the seat?
 - What is the tension in the chain?
 - What is the speed of the chair with the child in it?
 - How would parts a – d change if the chains were not massless, but each had a mass of 4kg?

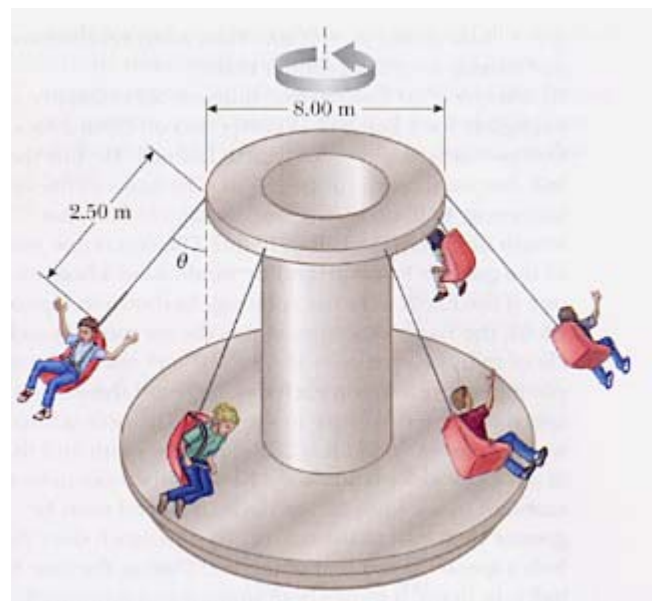

8. A model airplane of mass 0.750kg flies in a horizontal circle at the end of a 60m control wire, with a speed of 35m/s. What is the tension in the wire if the plane makes a constant angle of 20° with the horizontal? The forces exerted on the plane are the pull of the control wire, the weight of the plane and the aerodynamic lift, which acts at 20° inward from the vertical as shown below.

